

SCHMATIC CONTENTS

- SHEET01 - TITLE PAGE
- SHEET02 - CONTROL BLOCK DIAGRAM
- SHEET03 - IO EXPANSION CONNECTOR
- SHEET04 - AK4588 DAC/DIR
- SHEET05 - DIGITAL I/O, CLOCKS, MUTE
- SHEET06 - ANALOG IN 0,1
- SHEET07 - ANALOG IN 2,3
- SHEET08 - ANALOG IN 4,5
- SHEET09 - ANALOG IN 6, 7
- SHEET10 - ANALOG OUT 0-3
- SHEET11 - ANALOG OUT 4-7
- SHEET12 - POWER +12/-12V CONVERTOR
- SHEET13 - POWER

REVISION STATUS OF SHEETS

| REV | 1 | 2 | 3 | 4 | 5 | 6 | 7 | 8 | 9 | 10 | APPLICATION | USED ON | DATE | BY |
|-----|---|---|---|---|---|---|---|---|---|----|-------------|---------|------|------------|
| | | | | | | | | | | | | | | DWN |
| | | | | | | | | | | | | | | R.R.P. |
| | | | | | | | | | | | | | | 06/01/2008 |
| | | | | | | | | | | | | | | CHK |
| | | | | | | | | | | | | | | T.W.K. |
| | | | | | | | | | | | | | | 06/01/2008 |
| | | | | | | | | | | | | | | ENGR |
| | | | | | | | | | | | | | | R.R.P. |
| | | | | | | | | | | | | | | 12/01/2006 |
| | | | | | | | | | | | | | | ENGR-MGR |
| | | | | | | | | | | | | | | R.R.P. |
| | | | | | | | | | | | | | | 06/01/2008 |
| | | | | | | | | | | | | | | QA |
| | | | | | | | | | | | | | | C.M.D. |
| | | | | | | | | | | | | | | 06/01/2008 |
| | | | | | | | | | | | | | | MFG |
| | | | | | | | | | | | | | | R.R.P. |
| | | | | | | | | | | | | | | 06/01/2008 |
| | | | | | | | | | | | | | | RLSE |
| | | | | | | | | | | | | | | R.R.P. |
| | | | | | | | | | | | | | | 06/01/2008 |

| | | | |
|--|---------------------------|-------------|-------------|
| SPECTRUM DIGITAL INCORPORATED | | | |
| Title: DA830 Multi-Channel Audio Board | | | |
| Page Contents: TITLE PAGE | | | |
| Size: B | DWG NO | 511062-0001 | Revision: D |
| Date: | Tuesday, January 20, 2009 | Sheet | 1 of 13 |

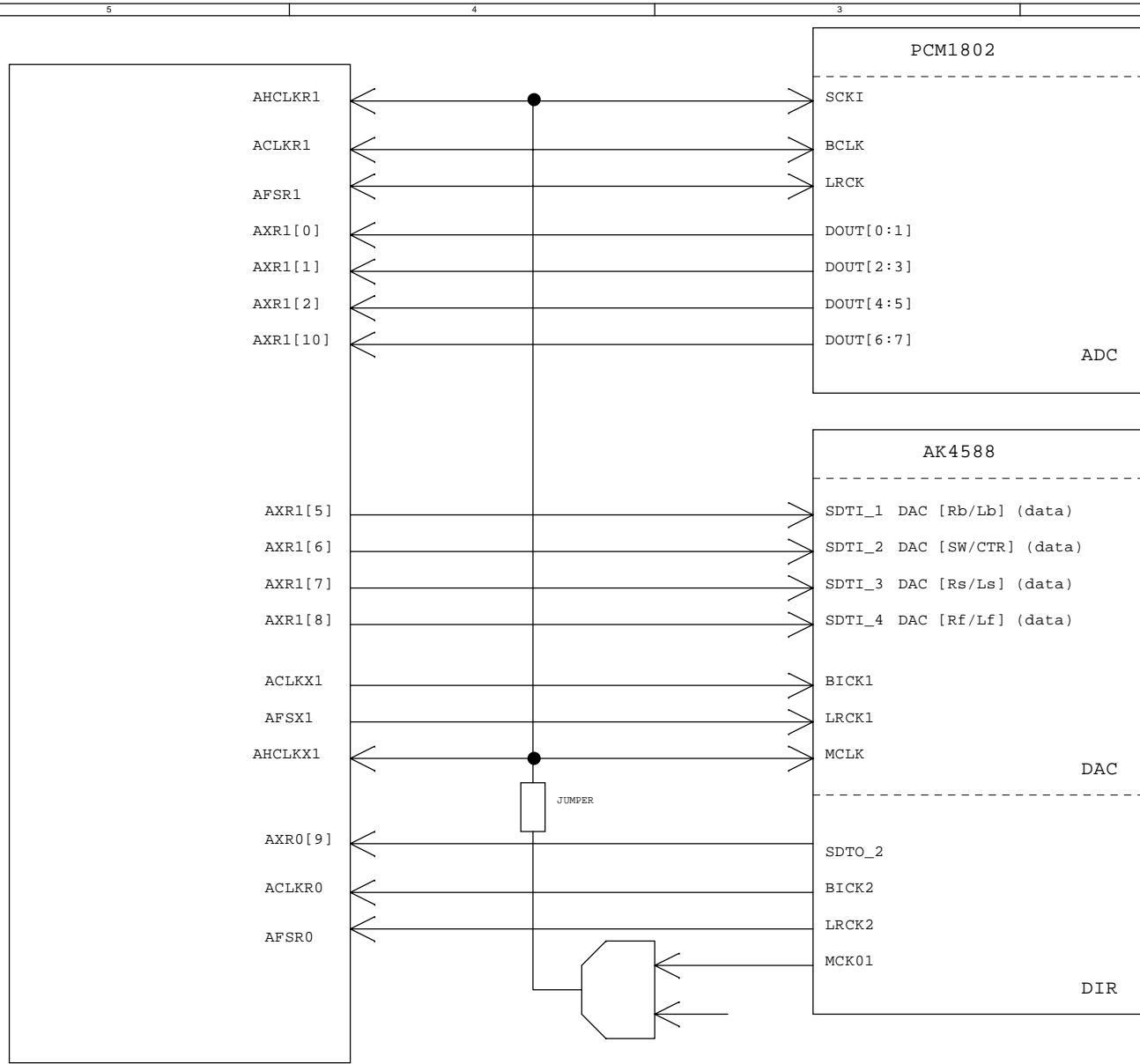

| | | | |
|--|---------------------------|-------------|-------------|
| SPECTRUM DIGITAL INCORPORATED | | | |
| Title: DA830 Multi-Channel Audio Board | | | |
| Page Contents: CONTROL DIAGRAM | | | |
| Size: B | DWG NO | 511062-0001 | Revision: C |
| Date: | Tuesday, January 20, 2009 | Sheet 2 of | 13 |

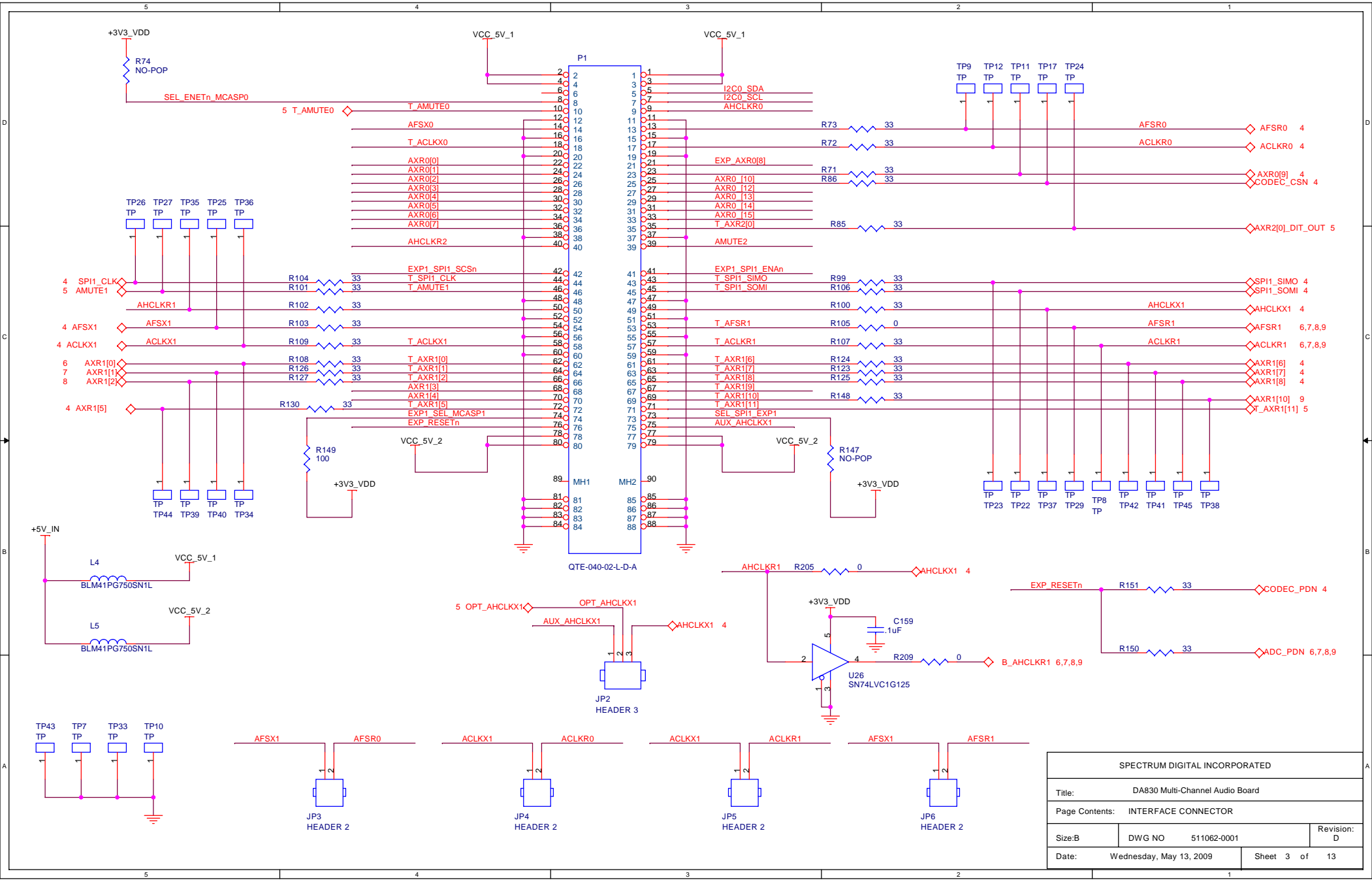

| | | | |
|--|---------------------|-------------|--|
| SPECTRUM DIGITAL INCORPORATED | | | |
| Title: DA830 Multi-Channel Audio Board | | | |
| Page Contents: INTERFACE CONNECTOR | | | |
| Size: B | DWG NO: 511062-0001 | Revision: D | |
| Date: Wednesday, May 13, 2009 | Sheet 3 of 13 | | |

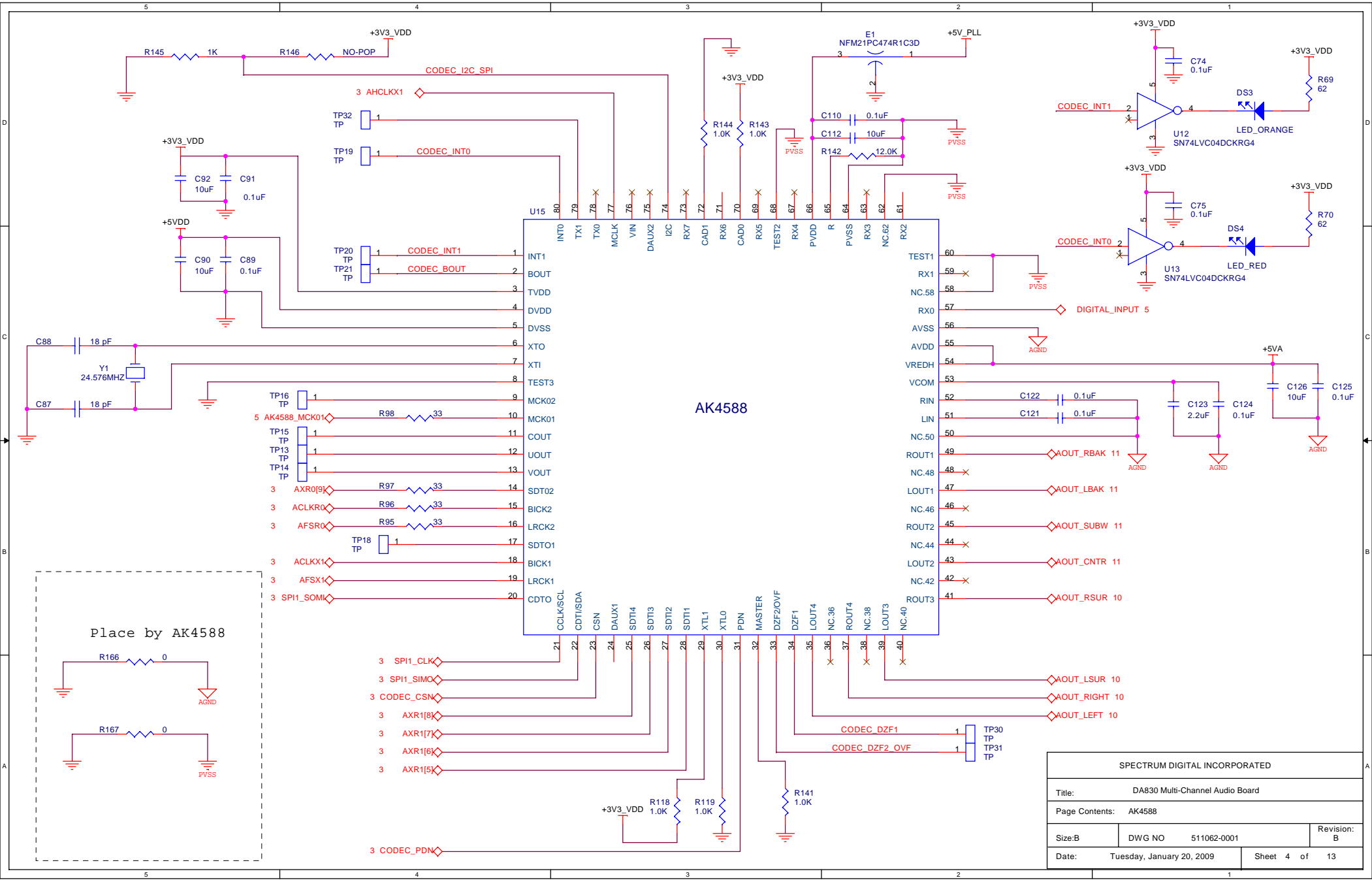

| | | | |
|--|---------------------------|-------------|-------------|
| SPECTRUM DIGITAL INCORPORATED | | | |
| Title: DA830 Multi-Channel Audio Board | | | |
| Page Contents: AK4588 | | | |
| Size: B | DWG NO | 511062-0001 | Revision: B |
| Date: | Tuesday, January 20, 2009 | Sheet 4 of | 13 |

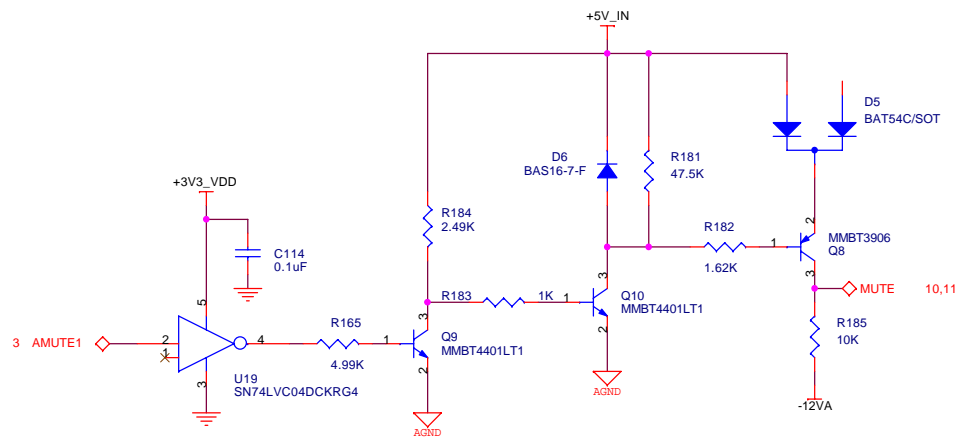
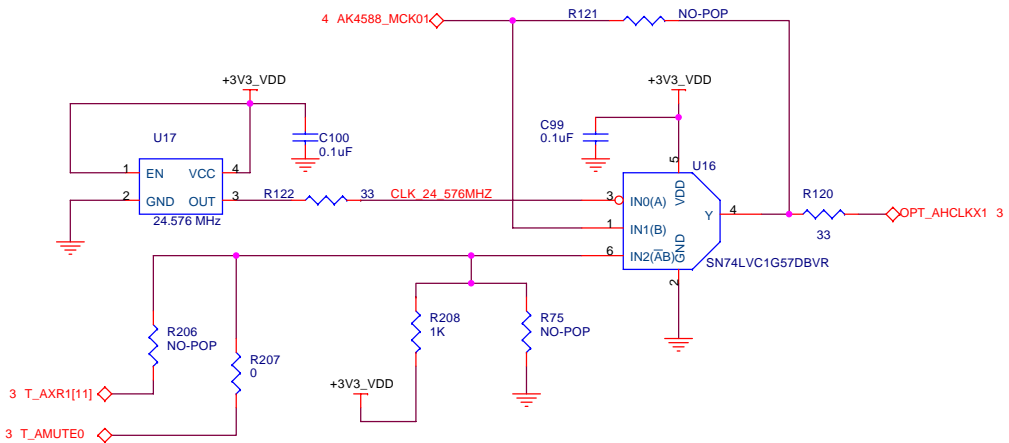
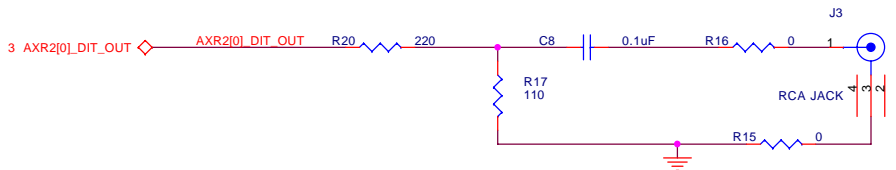
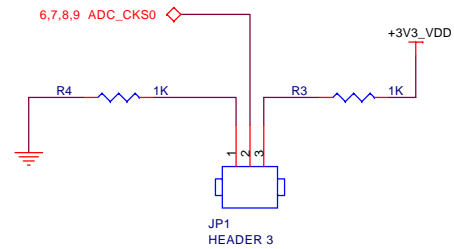
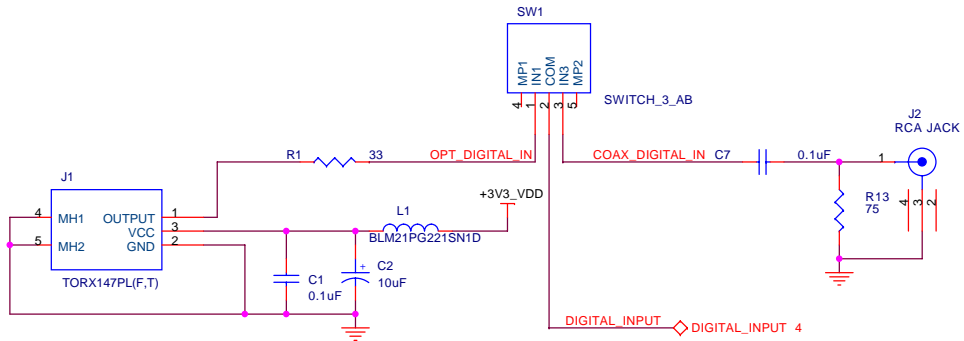

| | | | |
|--|---------------------------|-------------|---------------|
| SPECTRUM DIGITAL INCORPORATED | | | |
| Title: DA830 Multi-Channel Audio Board | | | |
| Page Contents: DIGITAL IO / MUTE/ CLKS | | | |
| Size: B | DWG NO | 511062-0001 | Revision: C |
| Date: | Tuesday, January 20, 2009 | | Sheet 5 of 13 |

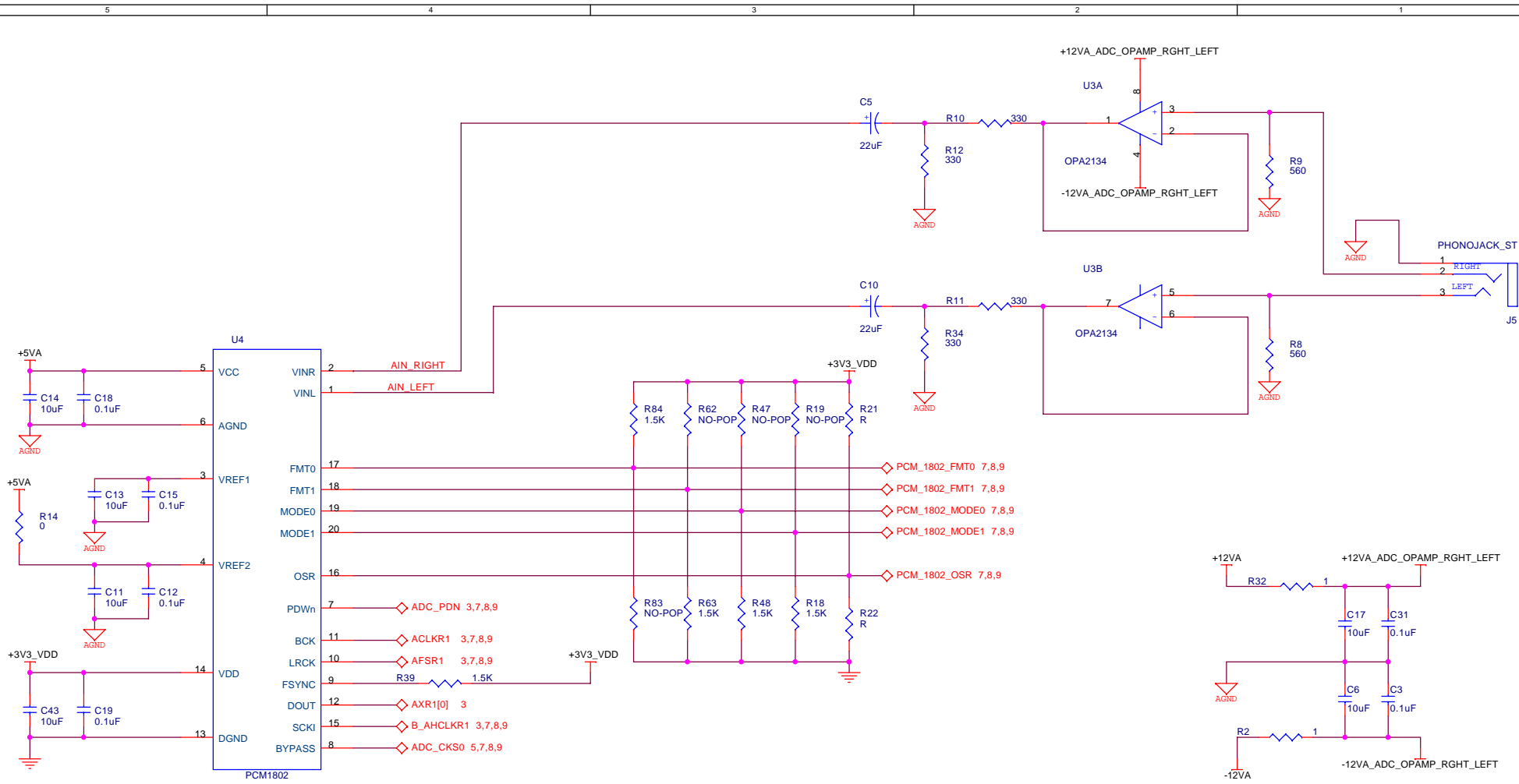

24 BIT I2S MODE - FMT 1:0 --> 01

MODE 0:1 --> 0:0 SLAVE 256FS,384FS,512FS,784FS

| | | | |
|--|---------------------------|-------------|-------------|
| SPECTRUM DIGITAL INCORPORATED | | | |
| Title: DA830 Multi-Channel Audio Board | | | |
| Page Contents: ANALOG INPUTS 0-1 | | | |
| Size: B | DWG NO | 511062-0001 | Revision: D |
| Date: | Tuesday, January 20, 2009 | Sheet 6 of | 13 |

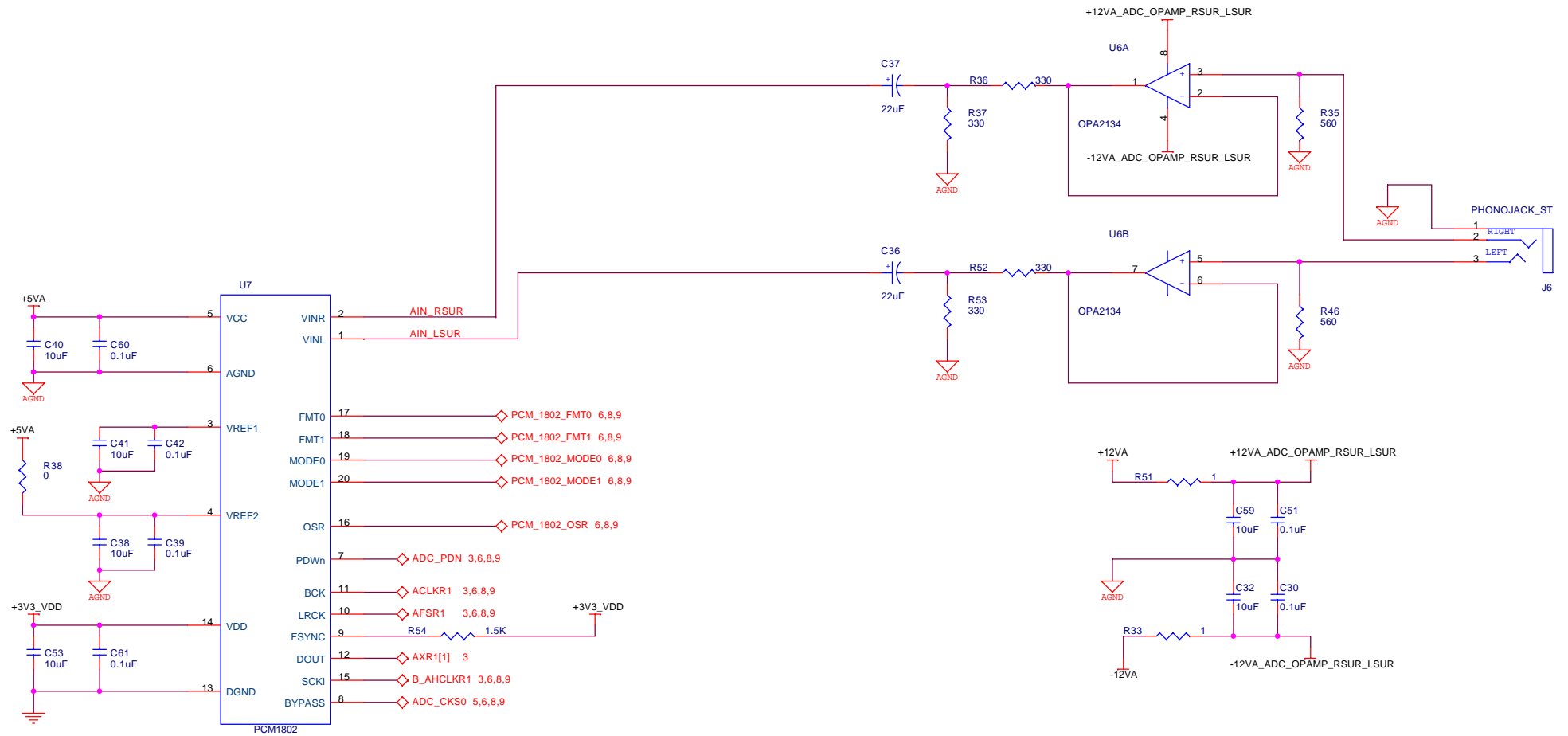

24 BIT I2S MODE - FMT 1:0 --> 01

MODE 0:1 --> 0:0 SLAVE 256FS,384FS,512FS,784FS

| | | | |
|--|---------------------------|-------------|-------------|
| SPECTRUM DIGITAL INCORPORATED | | | |
| Title: DA830 Multi-Channel Audio Board | | | |
| Page Contents: ANALOG INPUTS 2-3 | | | |
| Size: B | DWG NO | 511062-0001 | Revision: D |
| Date: | Tuesday, January 20, 2009 | Sheet 7 | of 13 |

24 BIT I2S MODE - FMT 1:0 --> 01
 MODE 0:1 --> 0:0 SLAVE 256FS,384FS,512FS,784FS

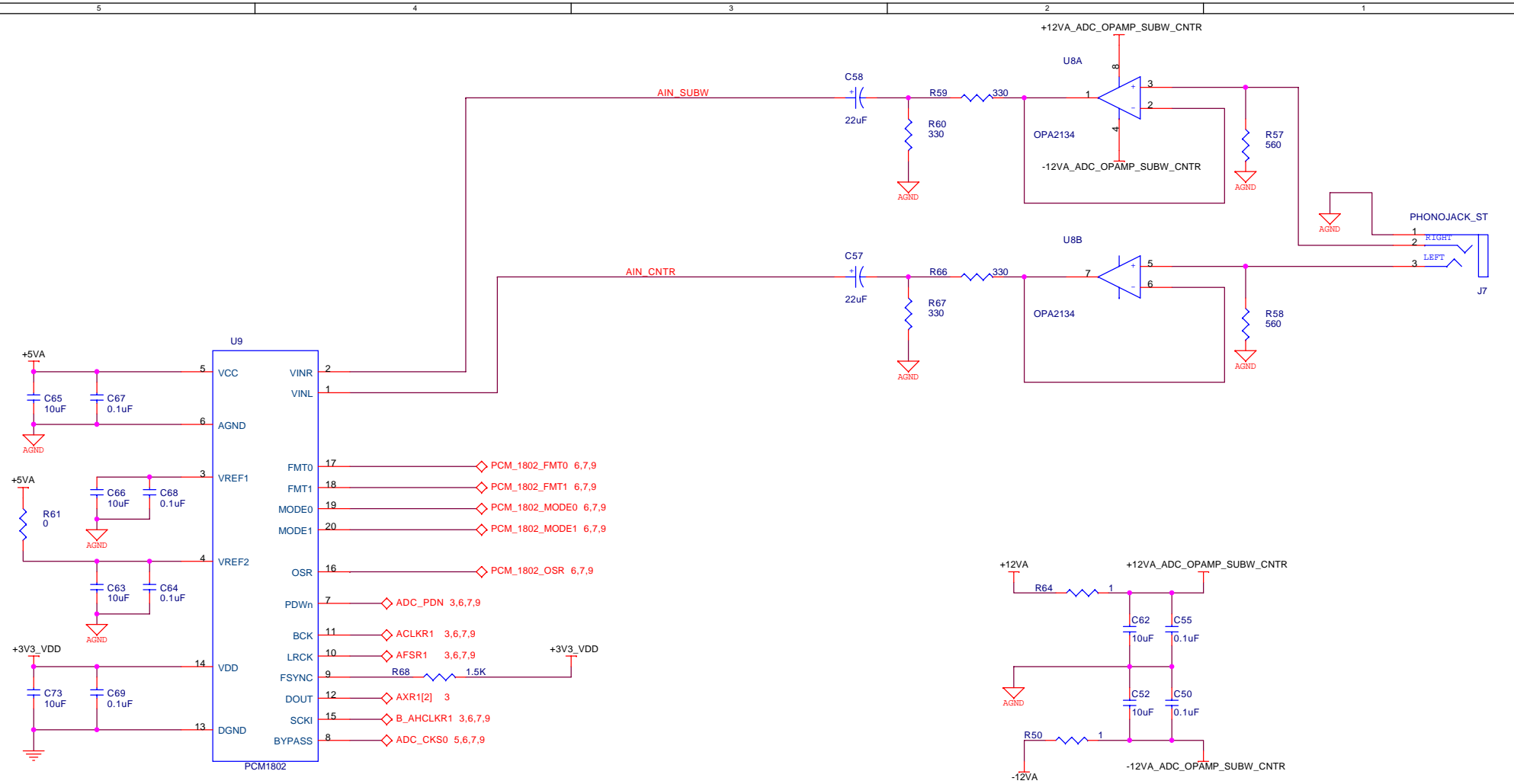

| | | | |
|--|---------------------------|-------------|-------------|
| SPECTRUM DIGITAL INCORPORATED | | | |
| Title: DA830 Multi-Channel Audio Board | | | |
| Page Contents: ANALOG INPUTS 4-5 | | | |
| Size: B | DWG NO | 511062-0001 | Revision: D |
| Date: | Tuesday, January 20, 2009 | Sheet 8 of | 13 |

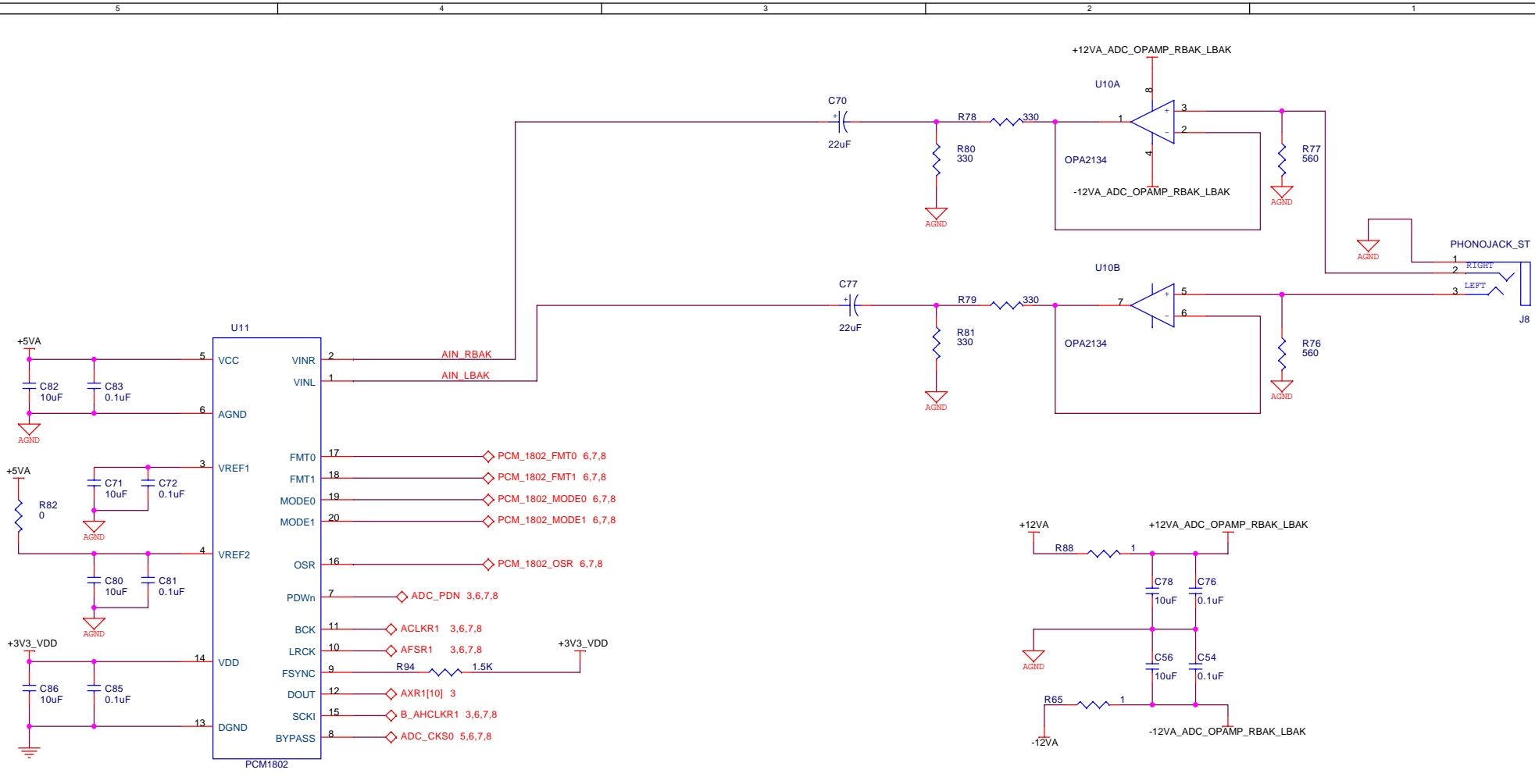

MODE 0:1 --> 0:0 SLAVE 256FS,384FS,512FS,784FS
 24 BIT I2S MODE - FMT 1:0 --> 01

| | | | |
|--|---------------------------|-------------|-------------|
| SPECTRUM DIGITAL INCORPORATED | | | |
| Title: DA830 Multi-Channel Audio Board | | | |
| Page Contents: ANALOG INPUTS 6-7 | | | |
| Size: B | DWG NO | 511062-0001 | Revision: D |
| Date: | Tuesday, January 20, 2009 | Sheet 9 | of 13 |

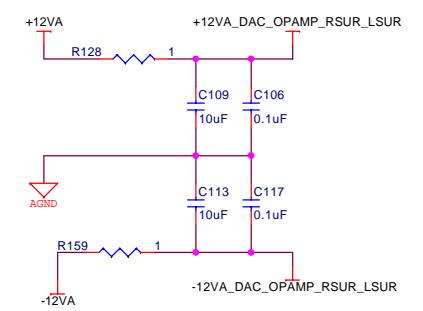
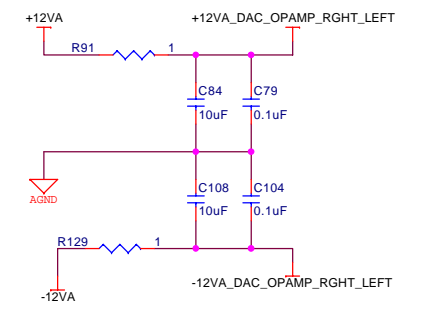
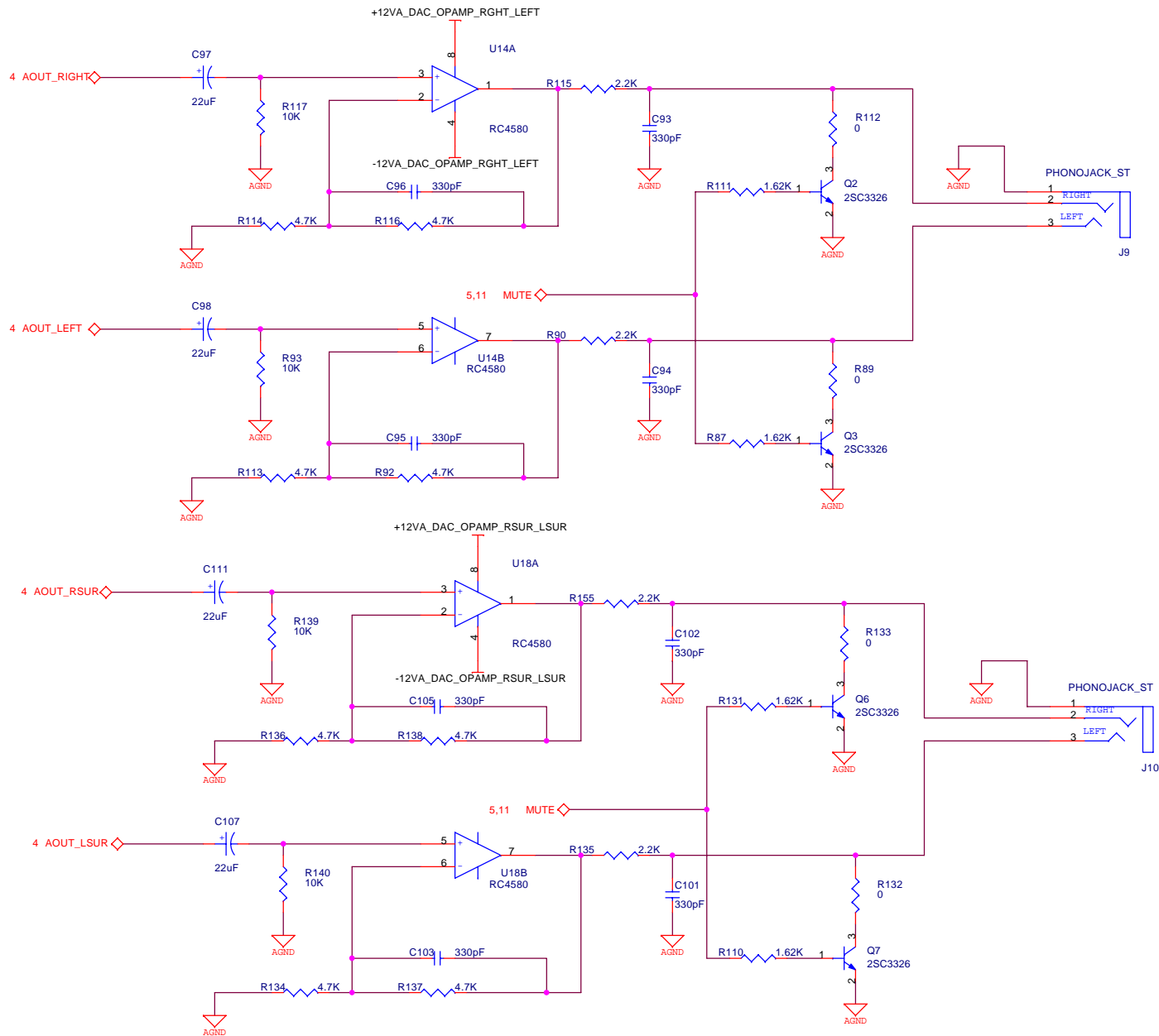

| | | | |
|--|---------------------------|-------------|-------------|
| SPECTRUM DIGITAL INCORPORATED | | | |
| Title: DA830 Multi-Channel Audio Board | | | |
| Page Contents: ANALOG OUTPUTS 0-3 | | | |
| Size: B | DWG NO | 511062-0001 | Revision: A |
| Date: | Tuesday, January 20, 2009 | Sheet | 10 of 13 |

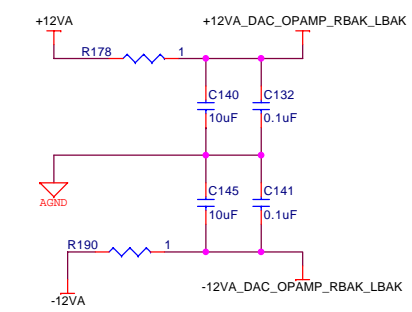
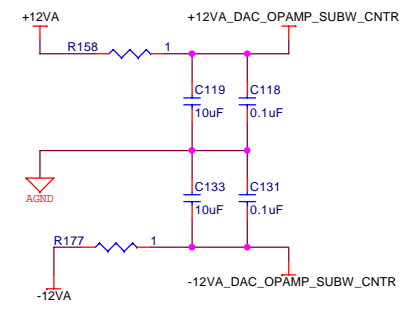
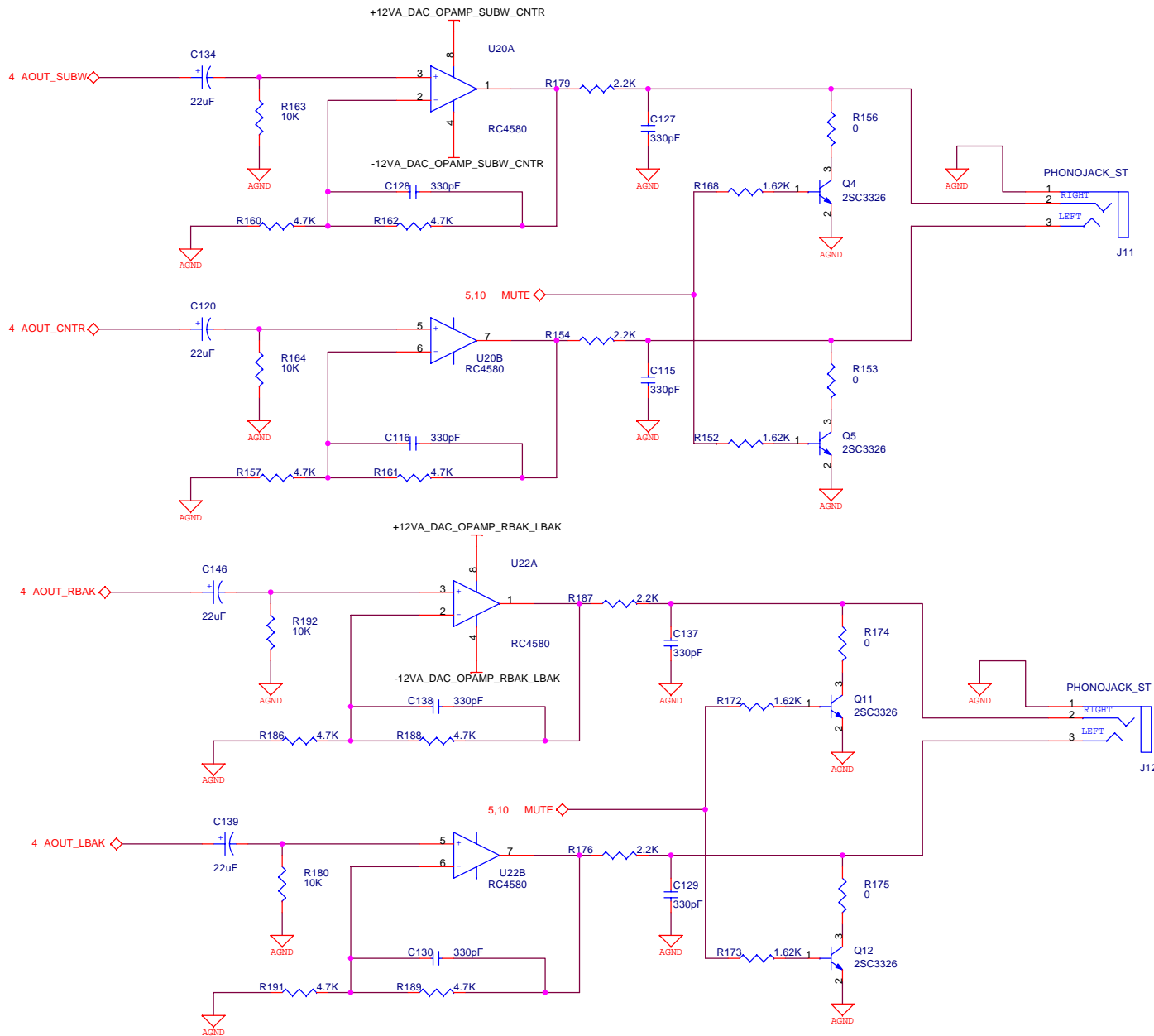

| | | | |
|--|---------------------------|-------------|-------------|
| SPECTRUM DIGITAL INCORPORATED | | | |
| Title: DA830 Multi-Channel Audio Board | | | |
| Page Contents: ANALOG OUTPUTS 4-7 | | | |
| Size: B | DWG NO | 511062-0001 | Revision: A |
| Date: | Tuesday, January 20, 2009 | Sheet | 11 of 13 |

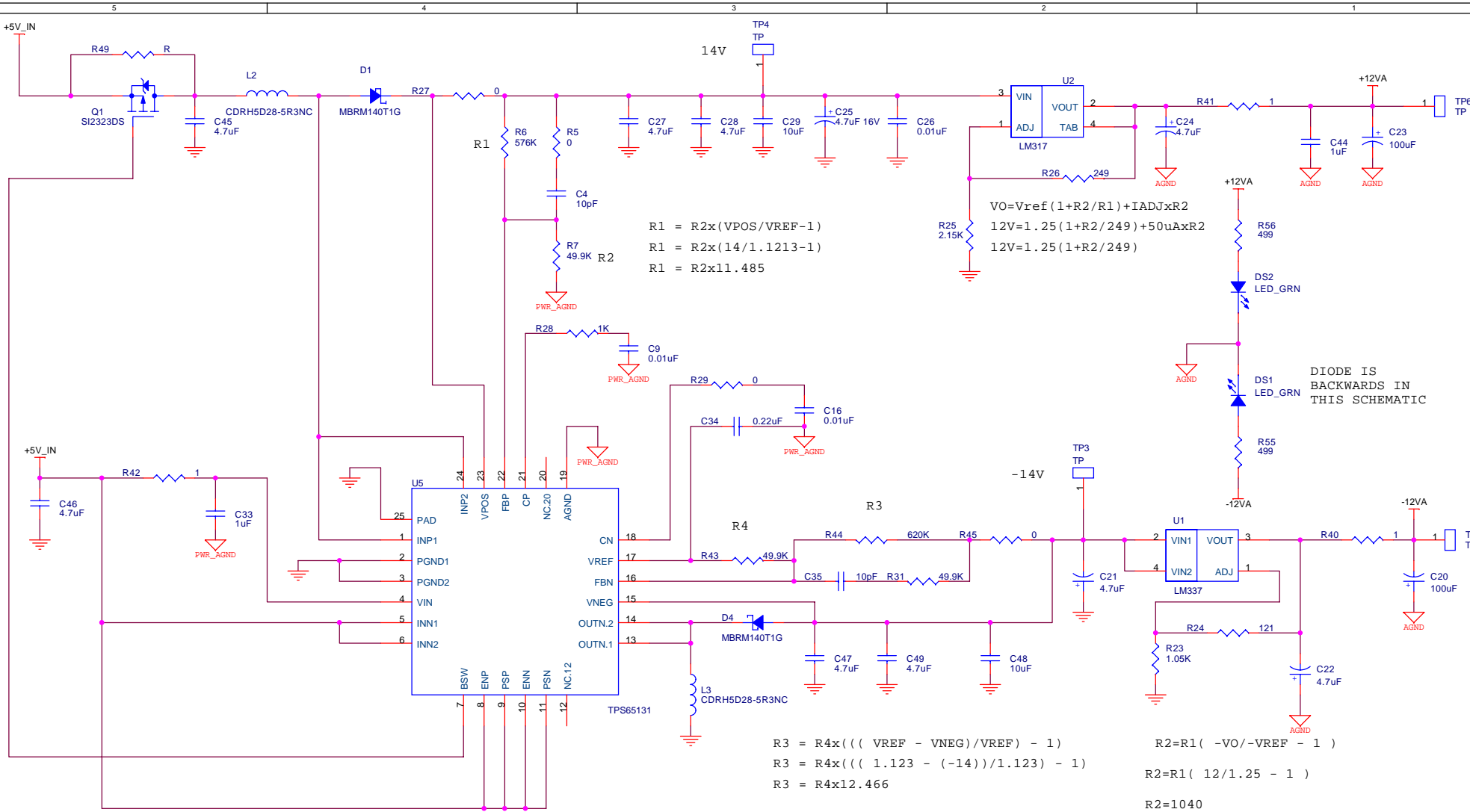

DIODE IS BACKWARDS IN THIS SCHEMATIC

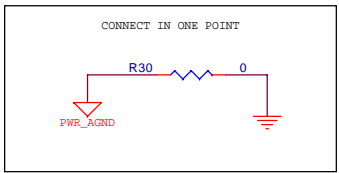

| | | | |
|--|---------------------------|-------------|-------------|
| SPECTRUM DIGITAL INCORPORATED | | | |
| Title: DA830 Multi-Channel Audio Board | | | |
| Page Contents: POWER SUPPLIES | | | |
| Size: B | DWG NO | 511062-0001 | Revision: A |
| Date: | Tuesday, January 20, 2009 | Sheet 12 of | 13 |

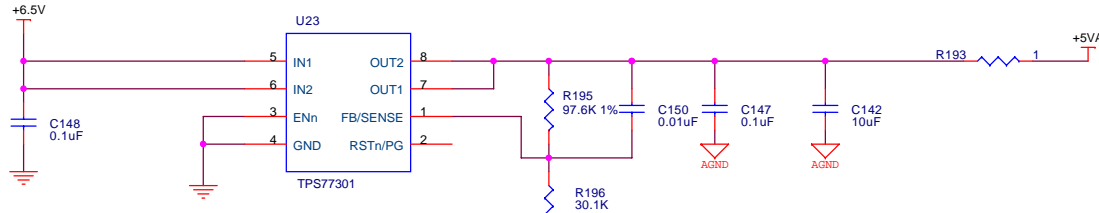
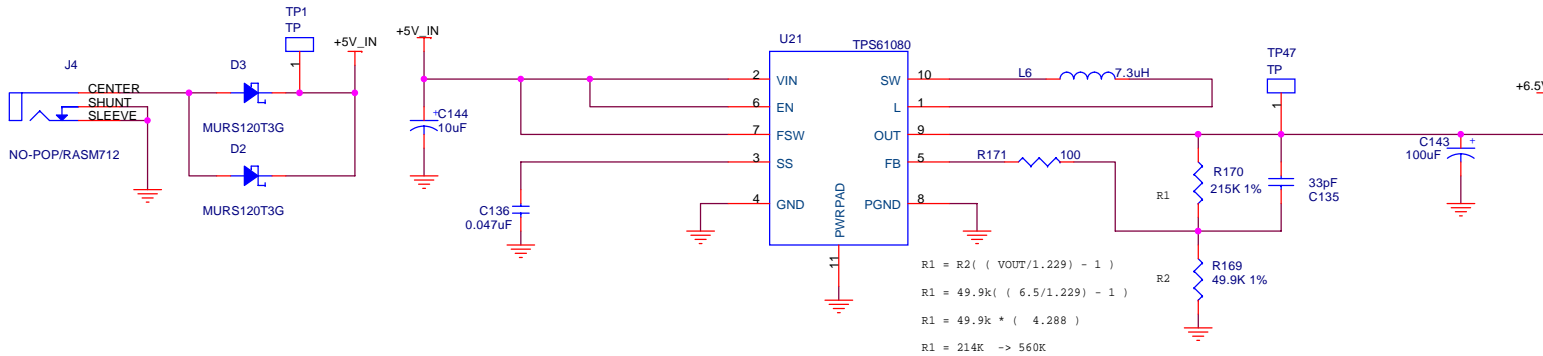

$$R1 = (VO / VREF - 1) \times R2$$

VREF = 1.1834 Volts

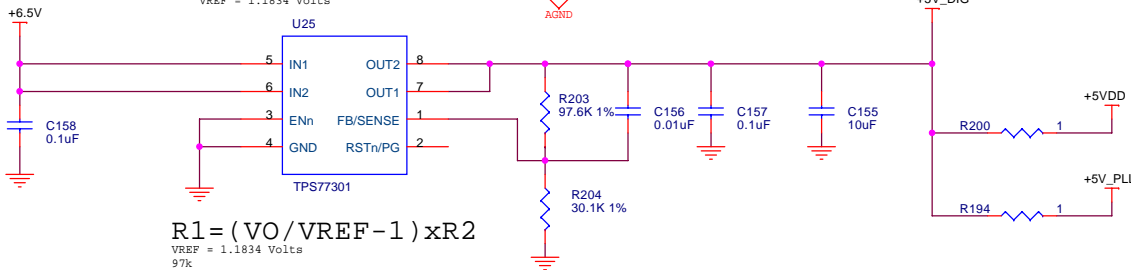

$$R1 = (VO / VREF - 1) \times R2$$

VREF = 1.1834 Volts
97k

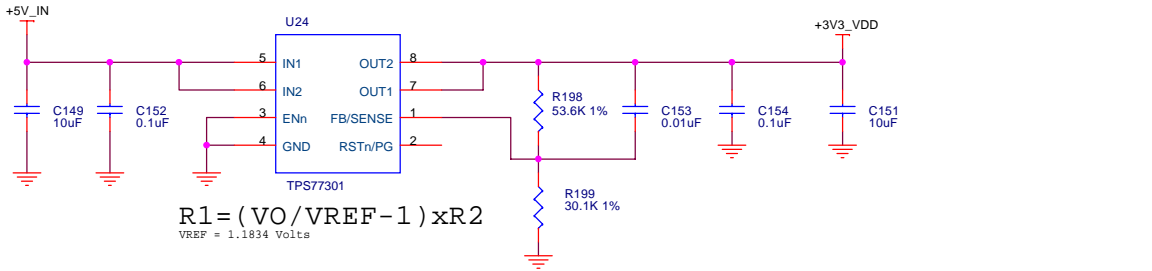

$$R1 = (VO / VREF - 1) \times R2$$

VREF = 1.1834 Volts

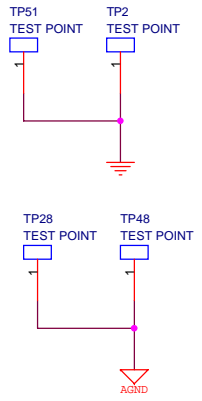
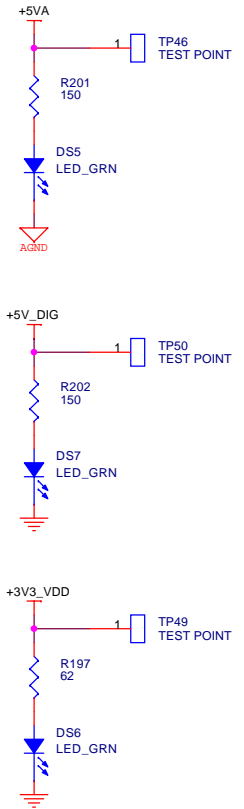

| | | | |
|--|---------------------------|-------------|-------------|
| SPECTRUM DIGITAL INCORPORATED | | | |
| Title: DA830 Multi-Channel Audio Board | | | |
| Page Contents: POWER INPUT | | | |
| Size: B | DWG NO | 511062-0001 | Revision: A |
| Date: | Tuesday, January 20, 2009 | Sheet 13 of | 13 |