

***ADV7343 Daughter Card for
DM6467 HD 1080P EVM***

*Technical
Reference*

ADV7343 Daughter Card for
DM6467 HD 1080P EVM
Technical Reference

512085-0001 Rev. A
November 2009

SPECTRUM DIGITAL, INC.
12502 Exchange Drive, Suite 440 Stafford, TX. 77477
Tel: 281.494.4505 Fax: 281.494.5310
sales@spectrumdigital.com www.spectrumdigital.com

IMPORTANT NOTICE

Spectrum Digital, Inc. reserves the right to make changes to its products or to discontinue any product or service without notice. Customers are advised to obtain the latest version of relevant information to verify that the data being relied on is current before placing orders.

Spectrum Digital, Inc. warrants performance of its products and related software to current specifications in accordance with Spectrum Digital's standard warranty. Testing and other quality control techniques are utilized to the extent deemed necessary to support this warranty.

Please be aware that the products described herein are not intended for use in life-support appliances, devices, or systems. Spectrum Digital does not warrant nor is Spectrum Digital liable for the product described herein to be used in other than a development environment.

Spectrum Digital, Inc. assumes no liability for applications assistance, customer product design, software performance, or infringement of patents or services described herein. Nor does Spectrum Digital warrant or represent any license, either express or implied, is granted under any patent right, copyright, or other intellectual property right of Spectrum Digital, Inc. covering or relating to any combination, machine, or process in which such Digital Signal Processing development products or services might be or are used.

WARNING

This equipment is intended for use in a laboratory test environment only. It generates, uses, and can radiate radio frequency energy and has not been tested for compliance with the limits of computing devices pursuant to subpart J of part 15 of FCC rules, which are designed to provide reasonable protection against radio frequency interference. Operation of this equipment in other environments may cause interference with radio communications, in which case the user at his own expense will be required to take whatever measures necessary to correct this interference.

Contents

1	Introduction to the ADV7343 Daughter Card	1-1
	<i>Provides you with a description of the ADV7343 Daughter Card, key features, and block diagram.</i>	
1.1	Key Features	1-2
1.2	ADV7343 Daughter Card Installation	1-4
2	Physical Specifications	3-1
	<i>Describes the physical layout of the ADV7343 Daughter Card and its interfaces.</i>	
2.1	Board Layout	2-2
2.2	Connectors	2-3
2.2.1	J1, Composite Video	2-3
2.2.2	J2, Pb Video Output	2-3
2.2.3	J3, Pr Video Output	2-4
2.2.4	J4, Y Video Output	2-4
2.2.5	P1, S-Video Connector	2-4
2.2.6	DC_P2, Expansion Connector	2-5
2.3	Test Points	2-7
2.4	Daughter Card Interface Control	2-8
A	Schematics	A-1
	<i>Contains the schematics for the ADV7343 Daughter Card</i>	
B	Mechanical Information	B-1
	<i>Contains the mechanical information about the ADV7343 Daughter Card</i>	

About This Manual

This document describes the board level operations of the ADV7343 Daughter Card. This daughter card plugs onto the DM6467 HD 1080P EVM. When both of these cards are used together it allows engineers and software developers to evaluate certain characteristics of the TMS320DM67647 HD 1080P processor to determine if the processor meets the designers application requirements. Evaluators can create software to execute on board or expand the system in a variety of ways.

Notational Conventions

This document uses the following conventions.

The ADV7343 Daughter Card will sometimes be referred to as the ADV7343 DC or DC.

Program listings, program examples, and interactive displays are shown in a special italic typeface. Here is a sample program listing.

```
equations  
!rd = !strobe&rw;
```

Information About Cautions

This book may contain cautions.

This is an example of a caution statement.

A caution statement describes a situation that could potentially damage your software, or hardware, or other equipment. The information in a caution is provided for your protection. Please read each caution carefully.

Related Documents, Application Notes and User Guides

Information regarding the TMS320DM6467 HD 1080P can be found at the following Texas Instruments website:

<http://www.ti.com>

Table 1: Manual History

Revision	History
A	Pre-Production Release

Table 2: Board History

PWB Revision	History
A	Pre-Production Release

Chapter 1

Introduction to the ADV7343 Daughter Card

Chapter One provides a description of the ADV7343 Daughter Card along with the key features of the circuit board.

Topic	Page
1.1 Key Features	1-2
1.2 ADV7343 Daughter Card Installation	1-4

1.1 Key Features

The ADV7343 Daughter Card is a plug on board for the TMS320DM6467 HD 1080P EVM. The ADV7343 DC gives the user the physical interfaces to interact with the EVM.

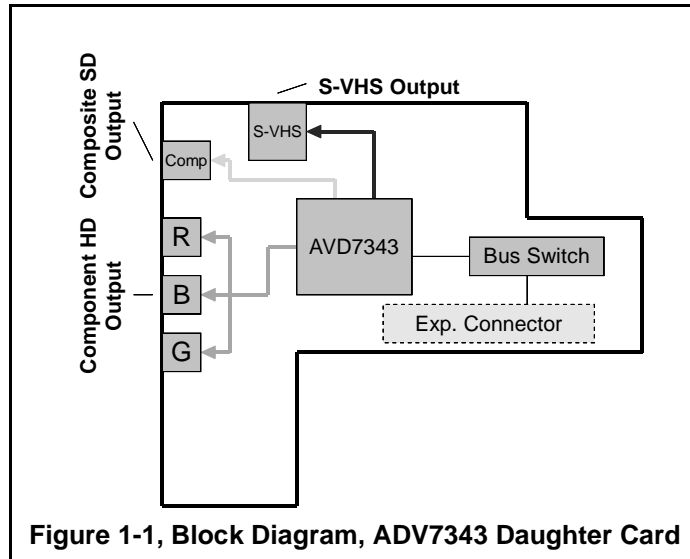

Key features of the ADV7343 DC include:

- ADV7343 six (6) channel encoder
- Composite video output (NTSC/PAL)
- S-video output
- Component video output (720P, 1080I, 1080P30)
- Direct interface to TMS320DM6467 HD 1080P EVM

Figure 1-2 below shows the ADV7343 Daughter Card for the DM6467 HD 1080P EVM.

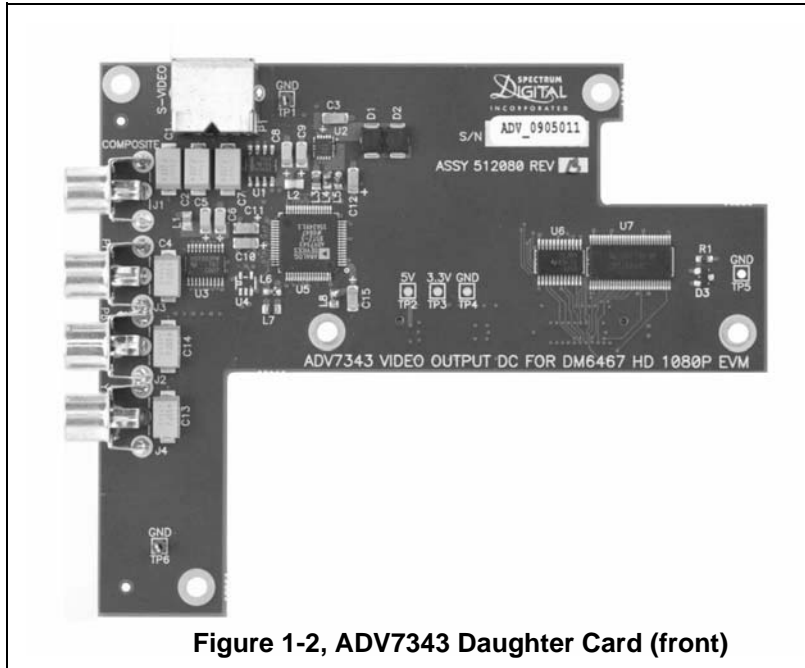

Figure 1-2, ADV7343 Daughter Card (front)

Figure 1-3 below shows the ADV7343 Daughter Card from the rear.

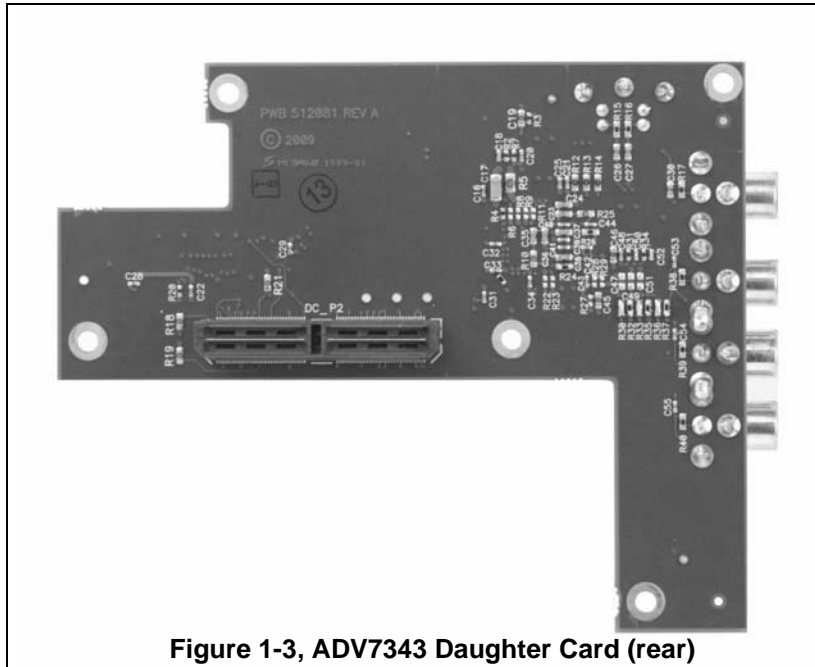
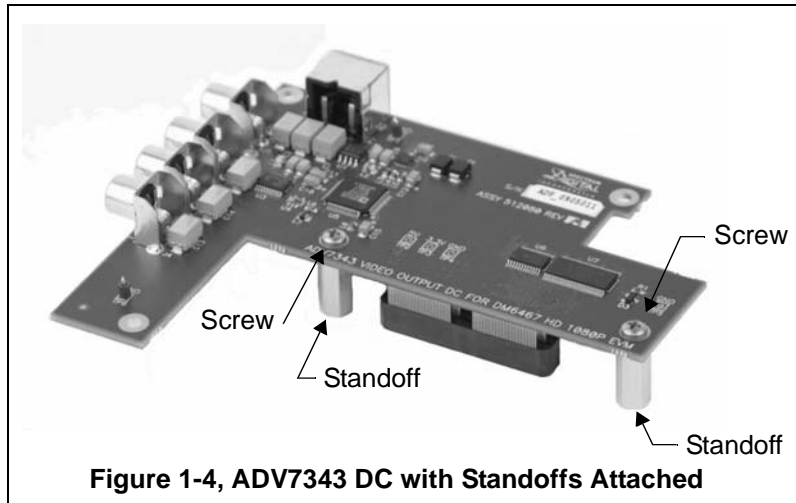

Figure 1-3, ADV7343 Daughter Card (rear)

1.2 ADV7343 Daughter Card Installation

The ADV7343 DC plugs directly onto the DM6467 HD 1080P EVM. To install this plug on board follow the procedure below.

1. If the DM6467 EVM is in a chassis turn off the computer and remove the EVM.
2. If the DM6467 is being used standalone remove the power to the EVM by turning off the power (SW4) and removing the power plug (J15).
3. Attached two 5/8 inch standoffs to the bottom side of the ADV7343 board with 2 screws as shown in the figure below.



4. Align the DC_P2 connector on the bottom side of the ADV7343 with the DC_P2 connector on the top side of the EVM.

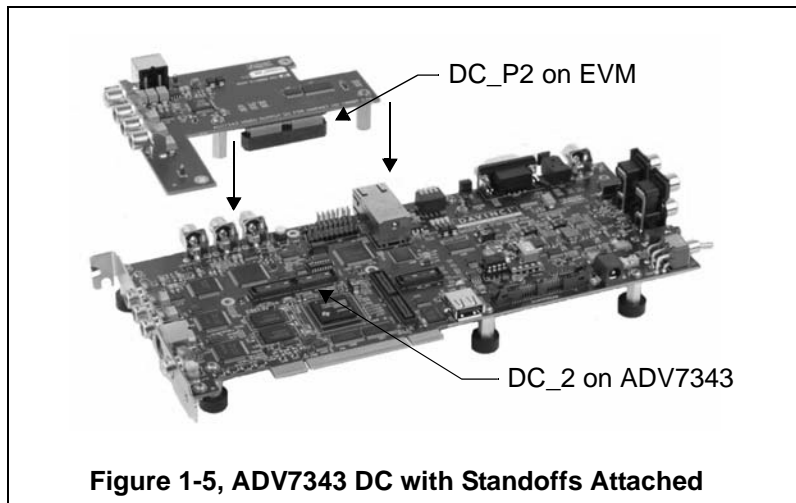

5. Carefully push down to seat the ADV7343 DC into the EVM. Do NOT apply undo pressure as this could cause damage to both boards. Visually inspect the connection to see that the ADV7343 DC is mounted correctly.

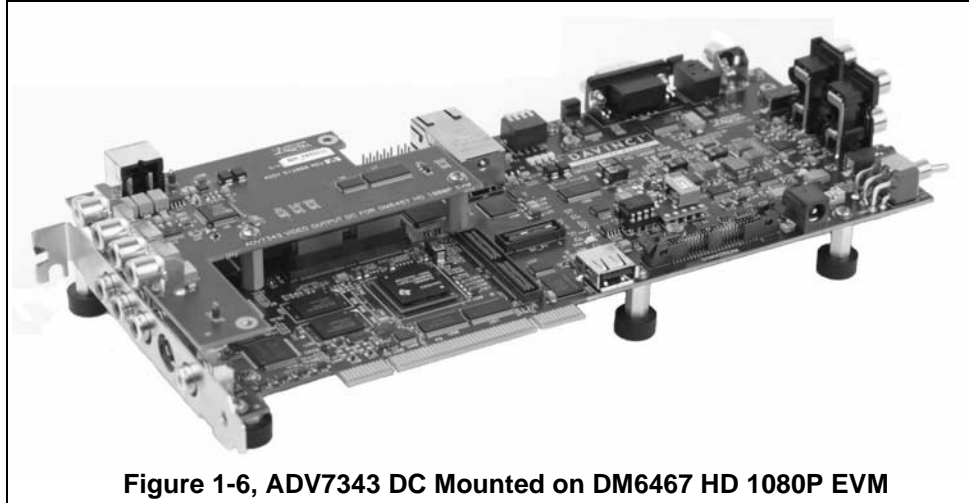

6. Install mounting screws into standoffs on the bottom side of the EVM.
7. If you are using the DM6467 EVM board standalone connect the video cables to the connectors on the ADV7343 DC. Insert the power cord back in connector J15. Then turn the power on to the board via switch SW4.
8. If you are using the DM6467 EVM board in a PC chassis make sure the power is off to the PC. Insert the combined EVM/ADV7343 DC into a PCI board slot. Connect the video cables to the connectors. Apply power or turn on the PC.

Chapter 2

Physical Description

This chapter describes the physical layout of the ADV7343 Daughter Card and its interfaces.

Topic	Page
2.1 Board Layout	2-2
2.2 Connectors	2-3
2.2.1 J1, Composite Video	2-3
2.2.2 J2, Pb Video Output	2-3
2.2.3 J3, Pr Video Output	2-4
2.2.4 J4, Y Video Output	2-4
2.2.5 P1, S-Video Connector	2-4
2.2.6 DC_P2, Video Expansion Connector	2-5
2.3 Test Points	2-7
2.4 Daughter Card Interface Control	2-8

2.1 Board Layout

The ADV7343 Daughter Card is a 4.70 x 5.75 inch (119 x 146 mm.) ten (10) layer printed circuit board which is powered by an external +5 volt only power supply. Figure 2-1 shows the layout of both sides of the ADV7343 Daughter Card.

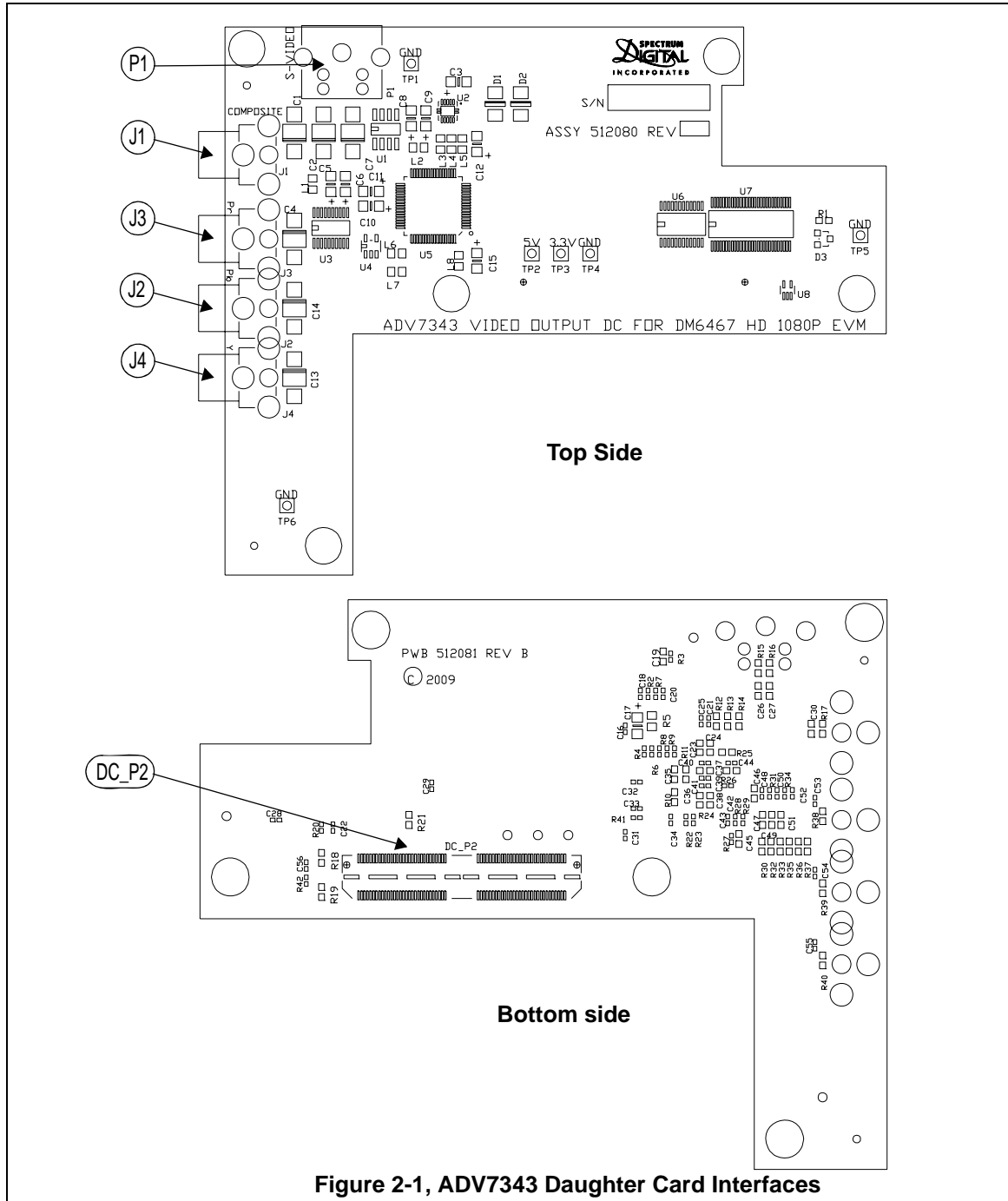

Figure 2-1, ADV7343 Daughter Card Interfaces

2.2 Connectors

The ADV7343 daughter Card has numerous connectors which provide connections to various peripherals. These connectors are described in the following sections.

Table 1: Connectors

Connector	Size	Side	Schematic Page	Color	Function
J1	2	Top	5	Yellow	Composite video
J2	2	Top	6	Blue	Pb
J3	2	Top	6	Red	Pr
J4	2	Top	6	Green	Y
P1	6	Top	5		S-video
DC_P2	2 X 60	Bottom	2		Video Expansion

2.2.1 J1, Composite Video

Connector J1 is a yellow RCA jack that brings out the composite video. This output is driven by the CH1-OUT signal on the THS7314 via ADV7343 DAC_D. The figure below shows this RCA jack.

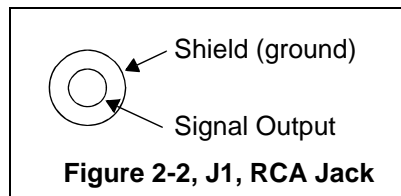

2.2.2 J2, Pb Video Output

Connector J2 is a blue RCA jack that brings out the Pb video component. This output is driven by the CH2-OUT signal on the THS7303 via ADV7343 DAC_B. The figure below shows this RCA connector.

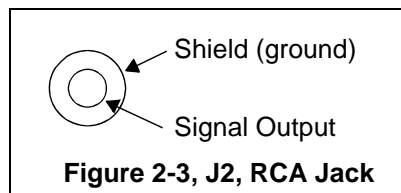

2.2.3 J3, Pr Video Output

Connector J3 is a red RCA jack that brings out the Pr video component. This output is driven by the CH1-OUT signal on the THS7303 via ADV7343 DAC_C. The figure below shows this RCA connector.

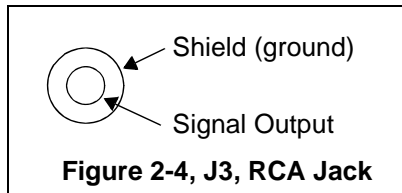

2.2.4 J4, Y Video Output

Connector J4 is a green RCA jack that brings out the Y video component. This output is driven by the CH3-OUT signal on the THS7303 via ADV7343 DAC_A. The figure below shows this RCA connector.

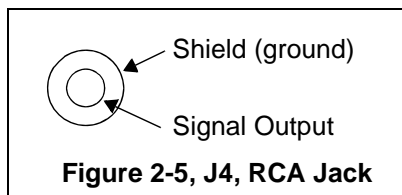

2.2.5 P1, S-Video Connector

Connector P1 is a 4 pin DIN connector that brings out the S-video. This output is driven by the CH2-OUT and CH3-OUT signals on the THS7314 via the ADV7343 DAC_E and DAC_F. The figure below shows the signals on this connector as viewed from the card edge.

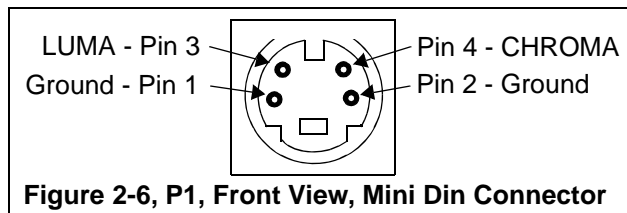

2.2.6 DC_P2, Video Expansion Connector

The DC_P2 is a 120 pin SAMTEC high speed connector that interfaces to the video logic on the TMS320DM6467 EVM. The pinout for the pins 1-60 of the DC_P2 connector are shown in the table below.

Table 2: DC_P2, Video Expansion Connector, Pins 1-60

Pin #	Signal	Pin #	Signal
1	ADV7343_ON_S0	2	VPIF_CLKOUT2
3	GROUND	4	GROUND
5	ADV7343_DC_PRESENT	6	ADV7343_ON_S1
7	GROUND	8	GROUND
9	VPIF_DOUT1	10	VPIF_DOUT0
11	VPIF_DOUT3	12	VPIF_DOUT2
13	VPIF_DOUT5	14	VPIF_DOUT4
15	VPIF_DOUT7	16	VPIF_DOUT6
17	GROUND	18	GROUND
19	VPIF_DOUT9	20	VPIF_DOUT8
21	VPIF_DOUT11	22	VPIF_DOUT10
23	VPIF_DOUT13	24	VPIF_DOUT12
25	VPIF_DOUT15	26	VPIF_DOUT14
27	GROUND	28	GROUND
29	VIDEO_OUT_EN1	30	VIDEO_OUT_EN0
31	GROUND	32	GROUND
33	NC	34	NC
35	GROUND	36	GROUND
37	NC	38	NC
39	GROUND	40	GROUND
41	NC	42	NC
43	GROUND	44	GROUND
45	NC	46	NC
47	NC	48	NC
49	GROUND	50	GROUND
51	NC	52	NC
53	NC	54	NC
55	NC	56	NC
57	NC	58	NC
59	ADV7343_ON_245	60	NC

The pinout for the pins 61-120 of the DC_P2 connector are shown in the table below.

Table 3: DC_P2, Video Expansion Connector, Pins 61-120

Pin #	Signal	Pin #	Signal
61	GROUND	62	GROUND
63	NC	64	NC
65	NC	66	NC
67	GROUND	68	GROUND
69	NC	70	NC
71	NC	72	NC
73	NC	74	NC
75	GROUND	76	GROUND
77	I2C_SDA	78	I2C_SCL
79	NC	80	NC
81	GROUND	82	NC
83	NC	84	NC
85	GROUND	86	NC
87	NC	88	NC
89	GROUND	90	GROUND
91	NC	92	NC
93	GROUND	94	GROUND
95	NC	96	NC
97	NC	98	NC
99	NC	100	NC
101	NC	102	NC
103	GROUND	104	GROUND
105	NC	106	NC
107	NC	108	NC
109	NC	110	NC
111	NC	112	NC
113	GROUND	114	GROUND
115	VCC_3V3	116	VCC_3V3
117	GROUND	118	GROUND
119	VCC_5V	120	VCC_5V

2.3 Test Points

The ADV7343 Daughter Card has 6 test points. All test points appear on the top of the board. The following figure identifies the position of each test point. The next table lists each test point and the signal appearing on that test point.

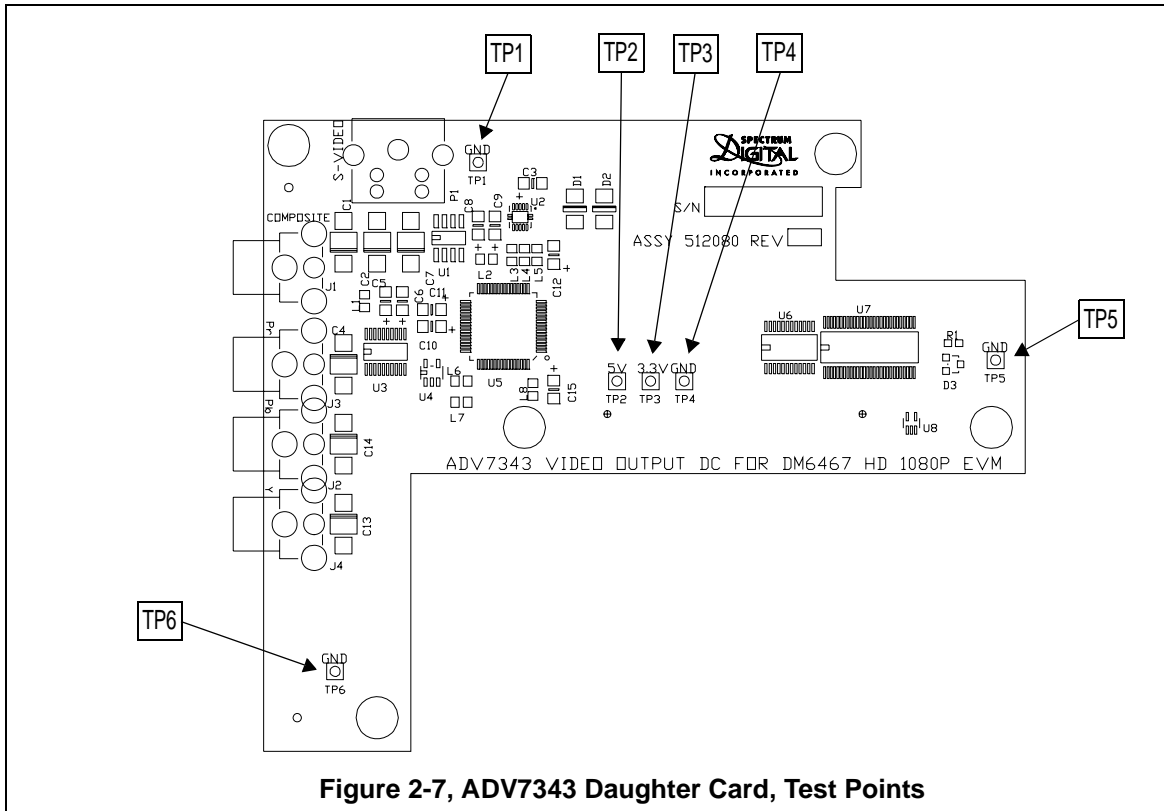

Figure 2-7, ADV7343 Daughter Card, Test Points

Table 4: ADV7343 Daughter Card Test Points

Test Point #	Schematic Page	Signal
TP1	6	GND
TP2	6	5V
TP3	6	3.3V
TP4	6	GND
TP5	6	GND
TP6	6	GND

2.4 Daughter Card Interface Control

When the ADV7343 Daughter Card is plugged into the DM6467 HD 1080P EVM the board is detected to be an ADV7343 Daughter Card via control signals on the expansion connector. The control signals interface to the CPLD on the DM6467 HD 1080P EVM and automatically route the video output port of the DM6467 device to the ADV7343 Daughter Card. Furthermore, the I²C interface to the THS8200 on the DM6467 HD 1080P is disabled to prevent conflicts in the I²C addressing between video encoders and video amplifiers on the two boards.

Appendix A

Schematics

This appendix contains the schematics for the ADV7343 Daughter Card.

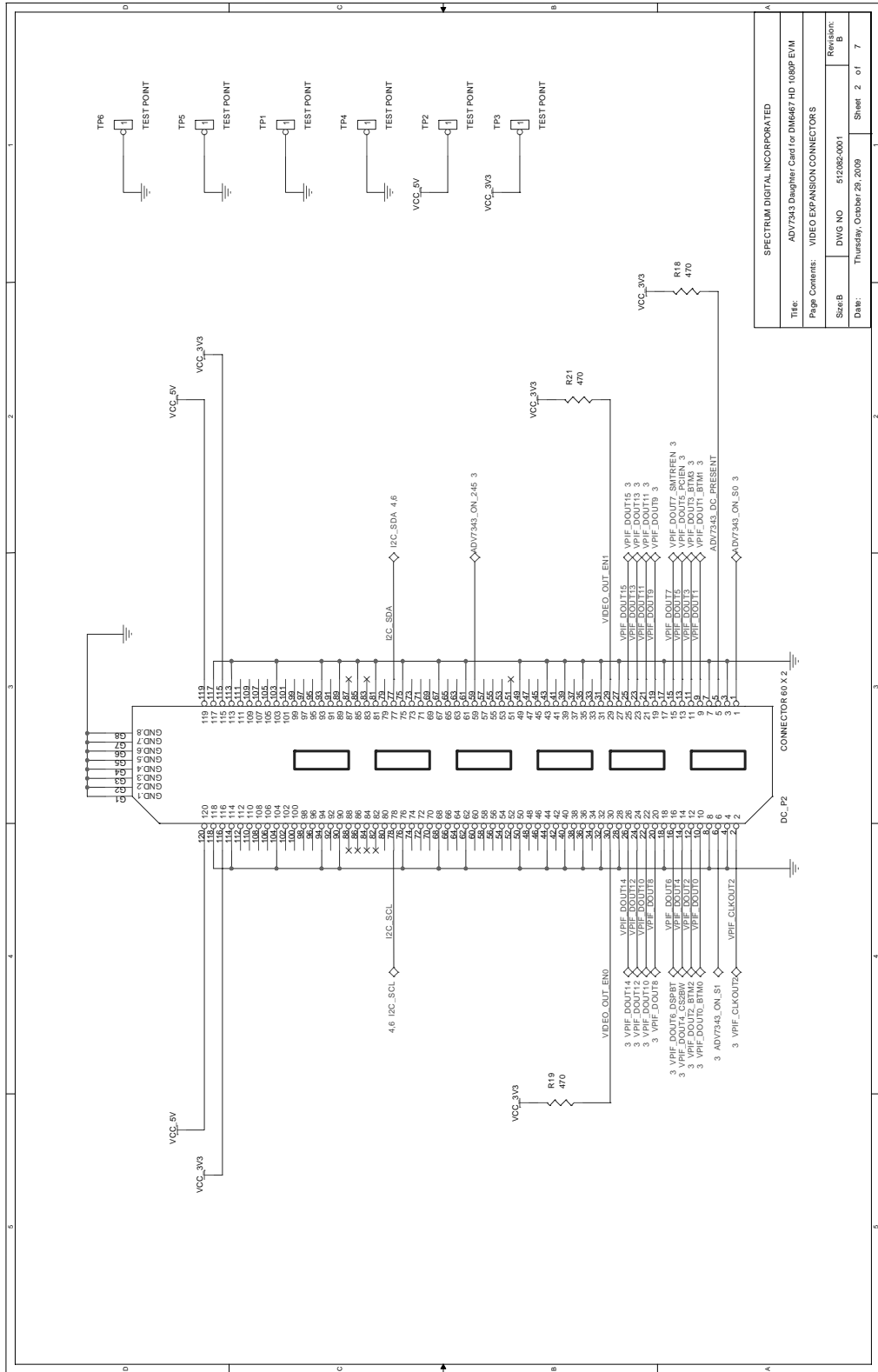

SPECTRUM DIGITAL INCORPORATED	
Title:	ADV7343 Daughter Card for DM6467 HD 1080P EVM
Page Contents:	VIDEO EXPANSION CONNECTORS
Size:	B
Revision:	B
Date:	Thursday, October 23, 2009
Sheet:	2 of 7

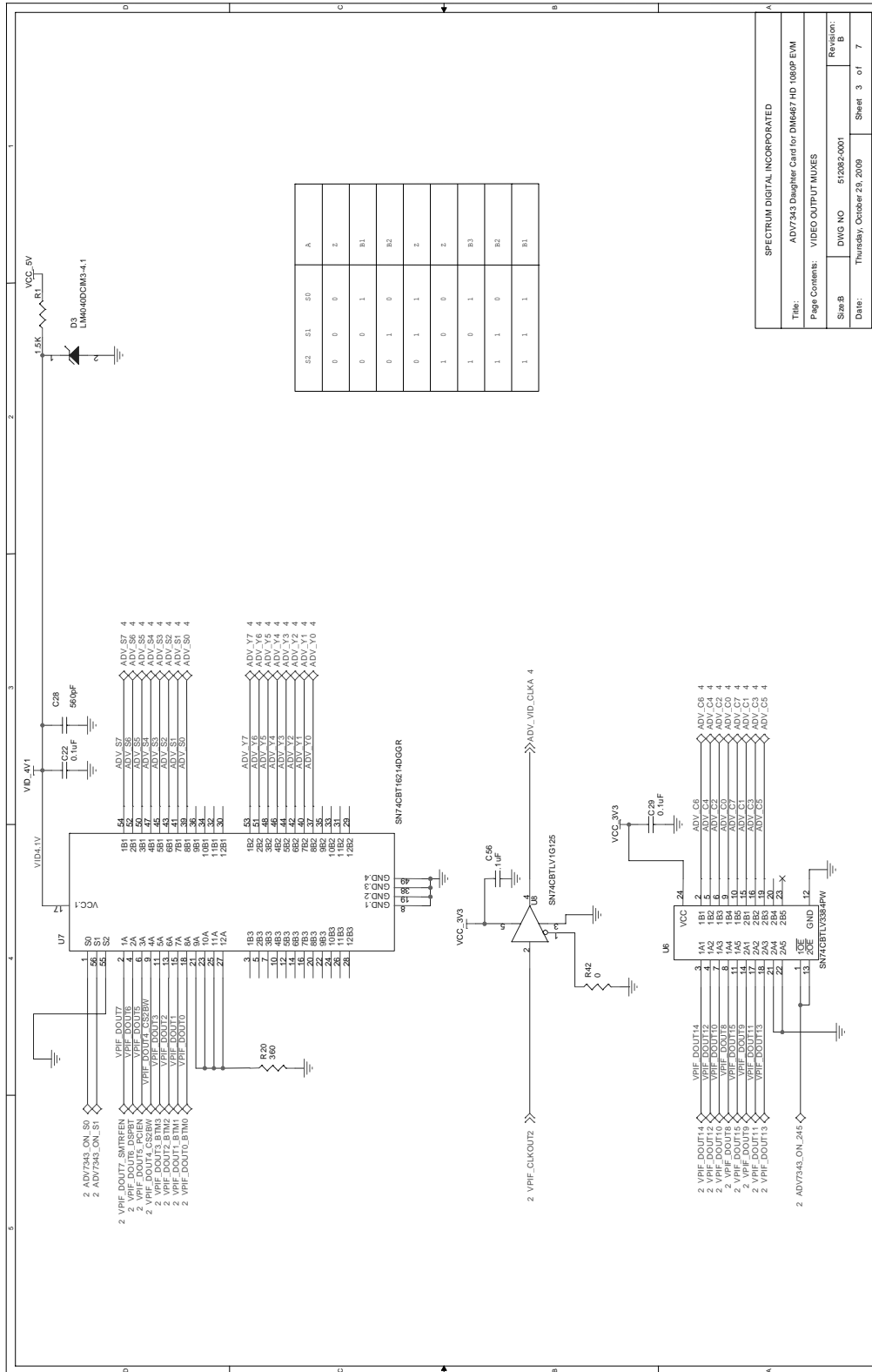

S2	S1	S0	A
0	0	0	2
0	0	1	B1
0	1	0	B2
0	1	1	2
1	0	0	2
1	0	1	B3
1	1	0	B2
1	1	1	B1

SPECTRUM DIGITAL INCORPORATED			
Title:	ADV7343 Daughter Card for DM6467 HD 1080P EVM		
Page Contents:	VIDEO OUTPUT MUXES		
Size B	DWG NO	512082-0001	Revision: B
Date:	Thursday, October 29, 2009		
	Sheet	3	of 7

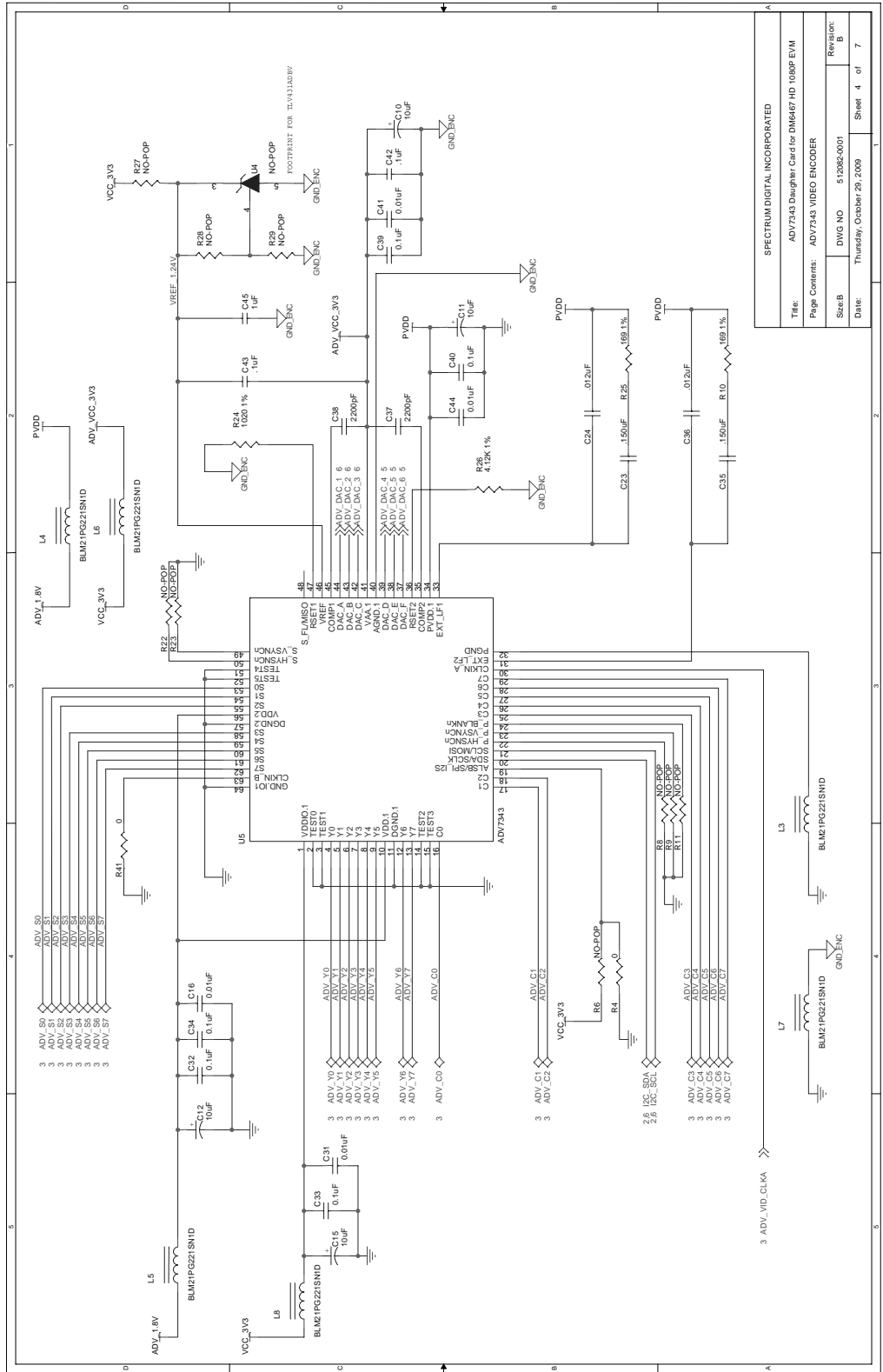

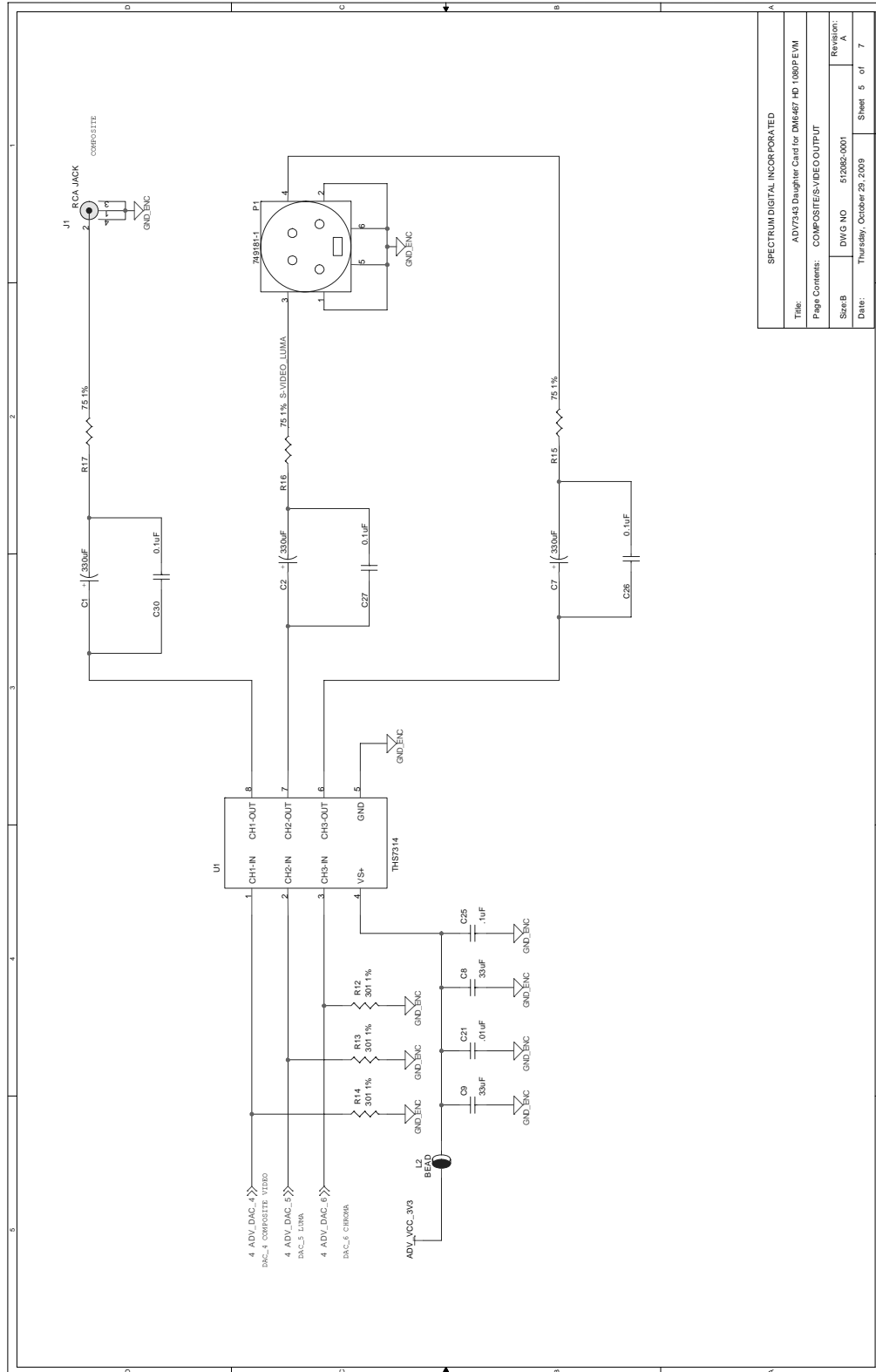

SPECTRUM DIGITAL INCORPORATED	
Title:	ADV7343 Daughter Card for DM6467 HD 1080P EVM
Page Contents:	COMPOSITE/VIDEO OUTPUT
Size B:	DWG NO 512685-0001
Date:	Thursday, October 29, 2009
Sheet	5 of 7
Revision:	A

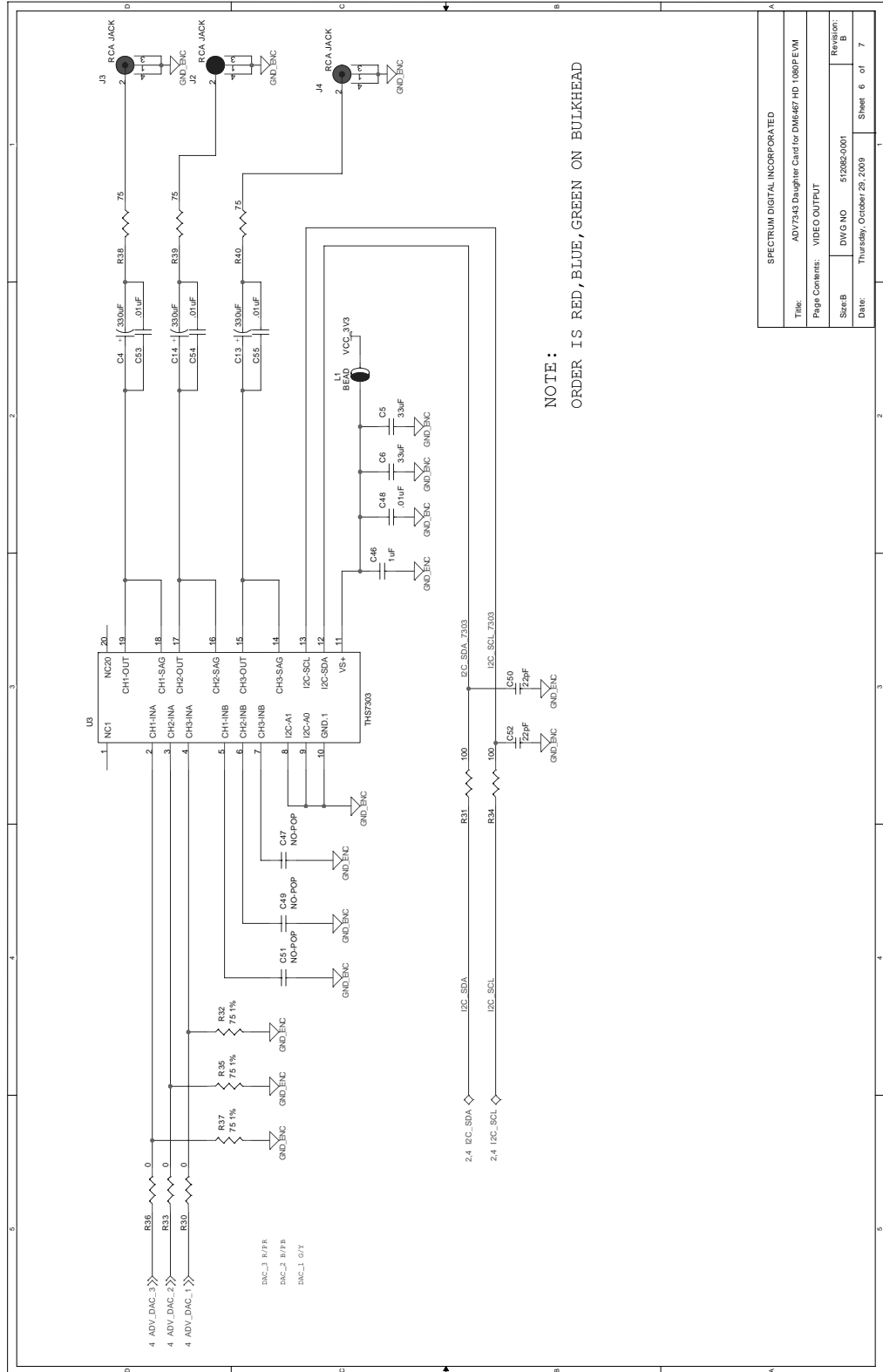

NOTE:
ORDER IS RED, BLUE, GREEN ON BULKHEAD

SPECTRUM DIGITAL INCORPORATED	
Title:	AD7543 Daughter Card for DM6467 HD 1080P FFM
Page Contents:	VIDEO OUTPUT
Size: B	DWG NO 512082-0101
Date:	Thursday, October 20, 2009
Revision:	B
Sheet	6 of 7

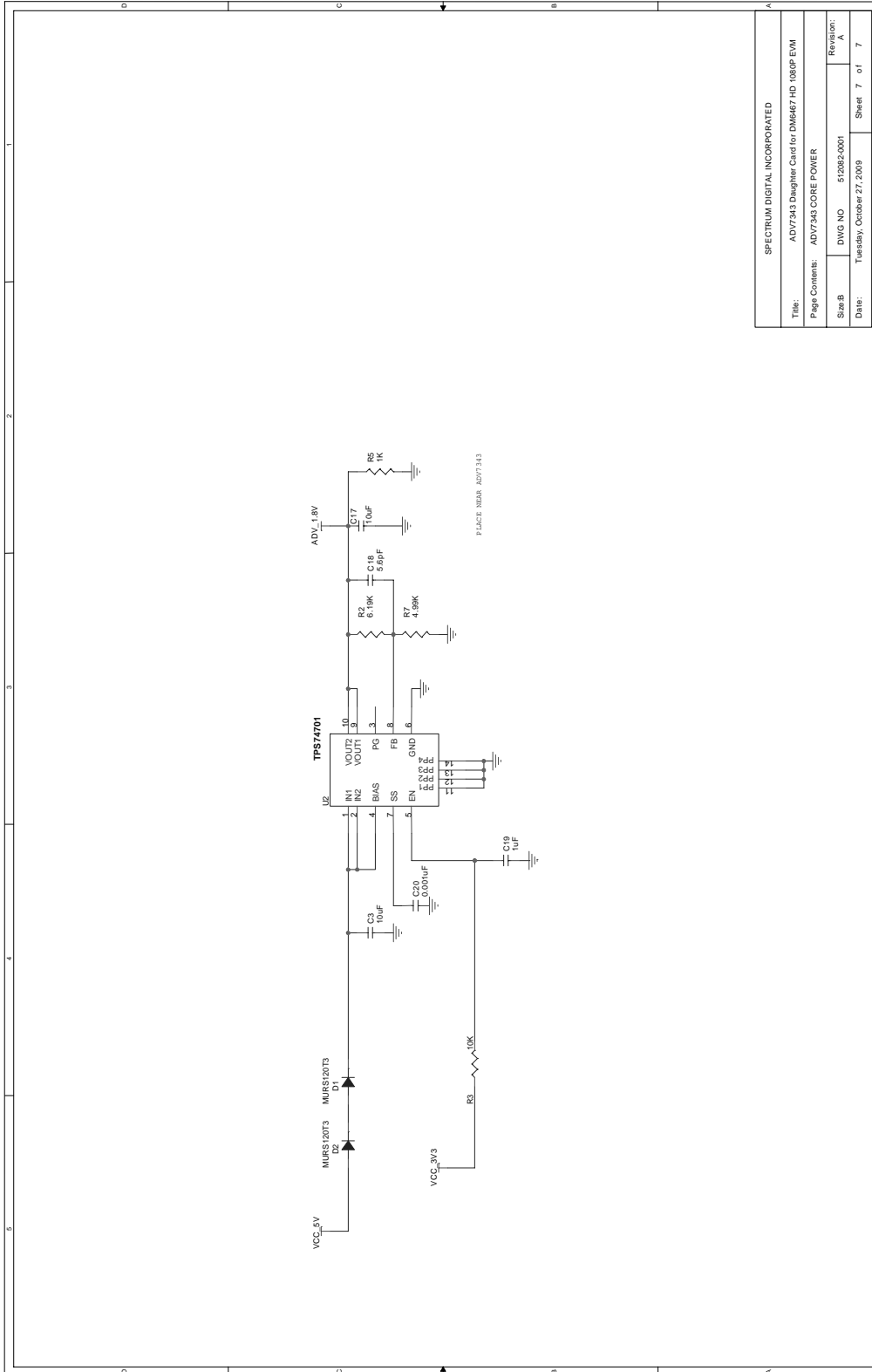

SPECTRUM DIGITAL INCORPORATED			
Title:	ADV7343 Daughter Card for DM6487 HD 1080P EVM		
Page Contents:	ADV7343 CORE POWER		
Sheet:	DWG NO	52882-001	Revision:
Date:	Tuesday, October 27, 2009		Sheet 7 of 7

Appendix B

Mechanical Information

This appendix contains the mechanical information about the ADV7343 Daughter Card produced by Spectrum Digital.

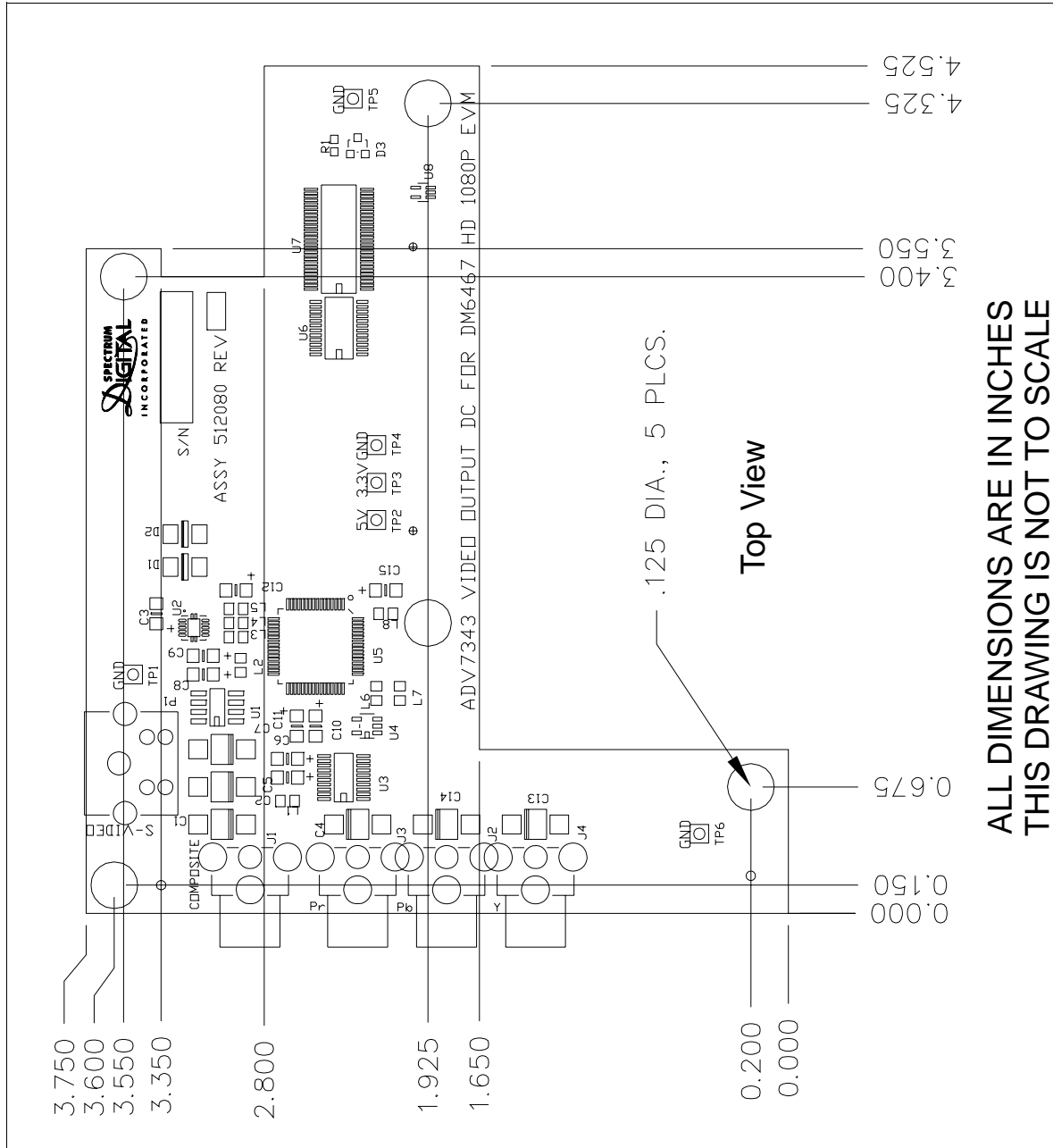

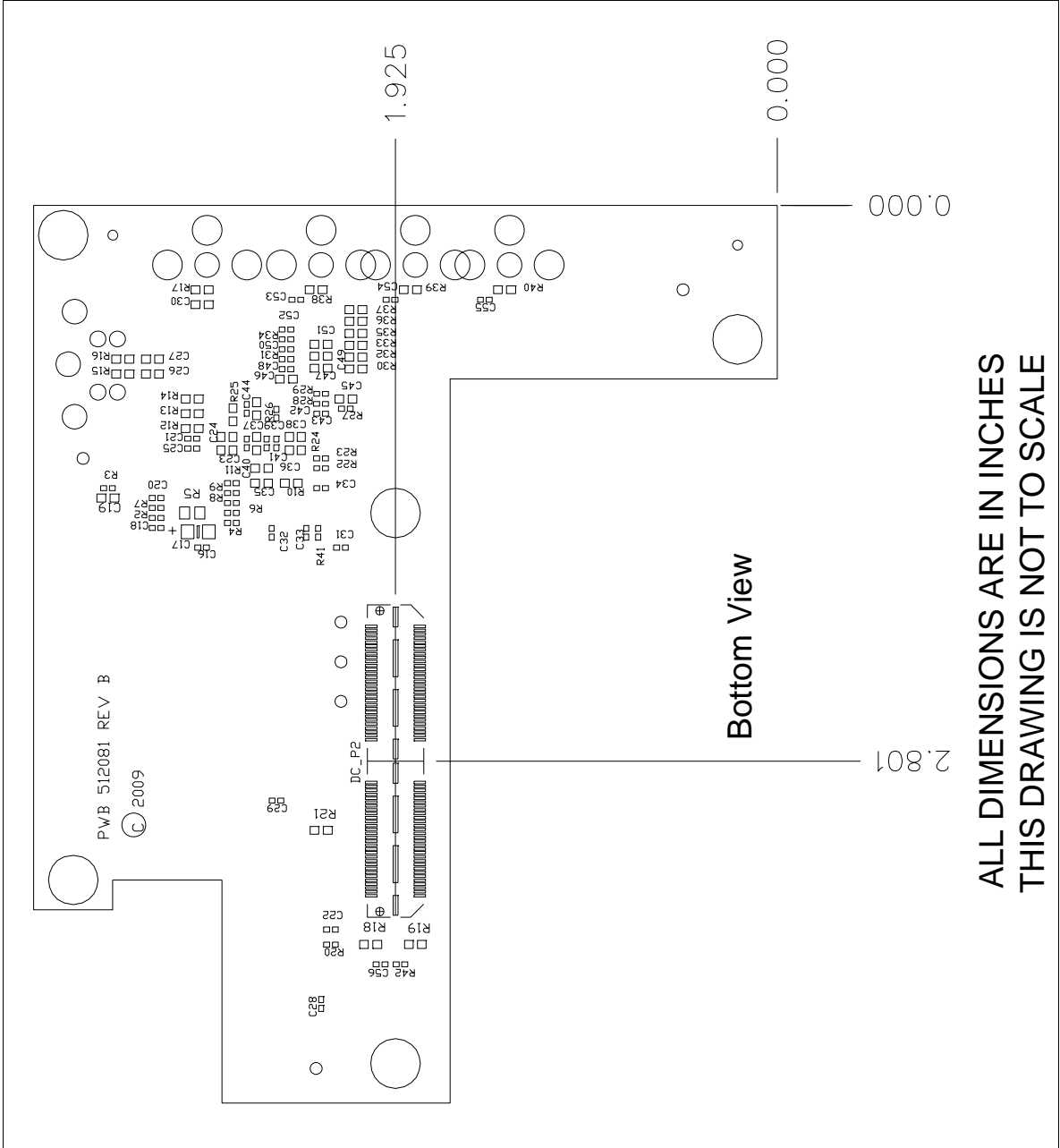

ALL DIMENSIONS ARE IN INCHES
THIS DRAWING IS NOT TO SCALE

