

Spectrum Digital Incorporated

Oct 15, 2008

Assembly 511340-0001

Revision: B to D

No Revision C exists, tracks other programs

Product Name: OMAP-L137 EVM

Affects:

SHEET7

SHEET11

SHEET14

SHEET 7

Pull downs added on USB_DM and USB_DP lines.
Change to fix pull downs that were not present on the L137 device
Change necessary for USB1 Host mode applications.
Added R120, R393

Revision B

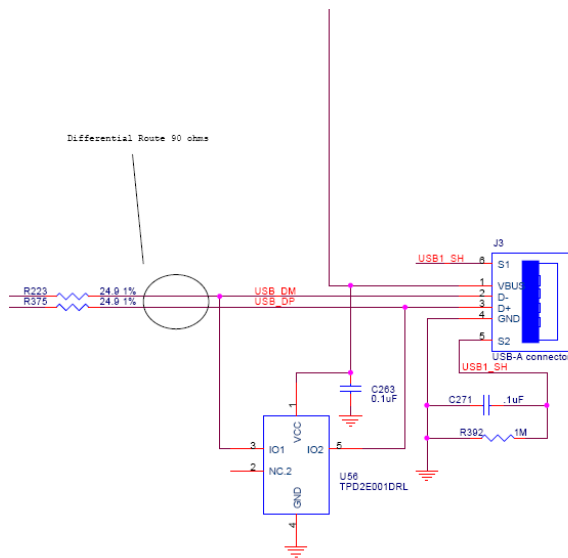

Revision D

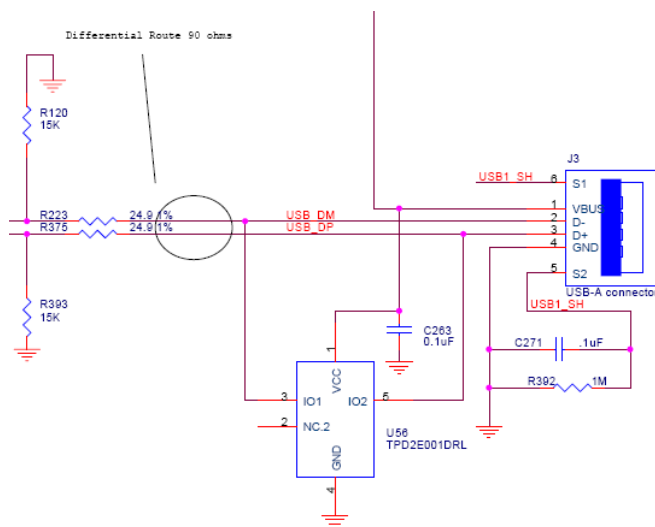

SHEET 11

Filter for PLL0_VDDA and PLL0_VSSA pins change, to match TI recommended circuit in the data sheet. Change provides no functional difference.
Deleted E6 and added L24, L25 and C272

Revision B

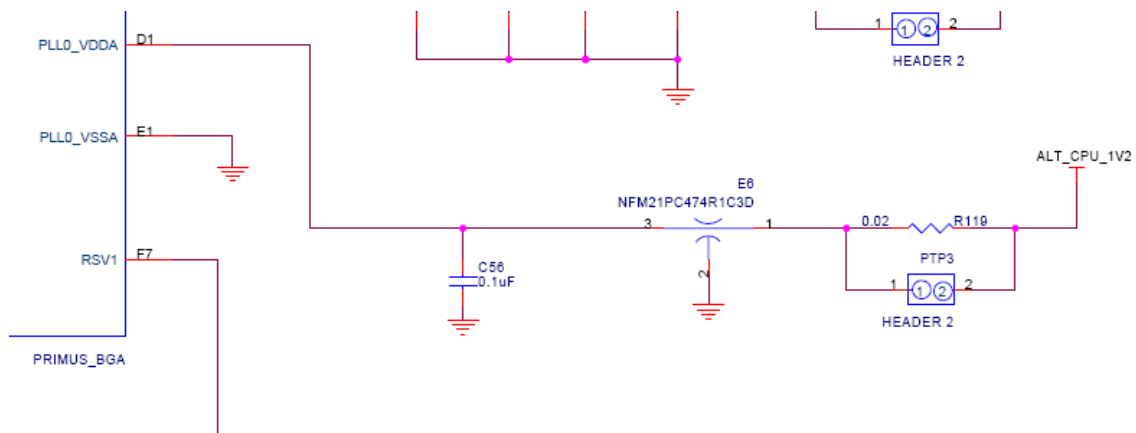

Revision D

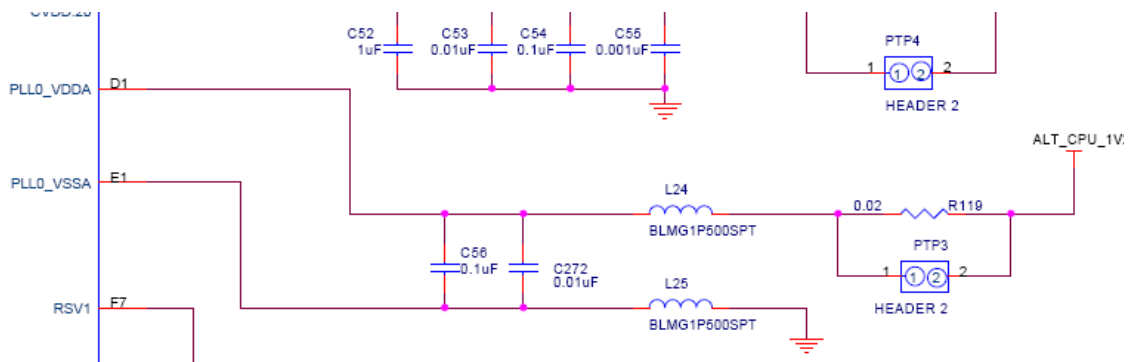

SHEET 11

Removed Power test point and Filter on pin RSV2. Change provides no functional difference.
Deleted E7, PTP2, R120

Revision B

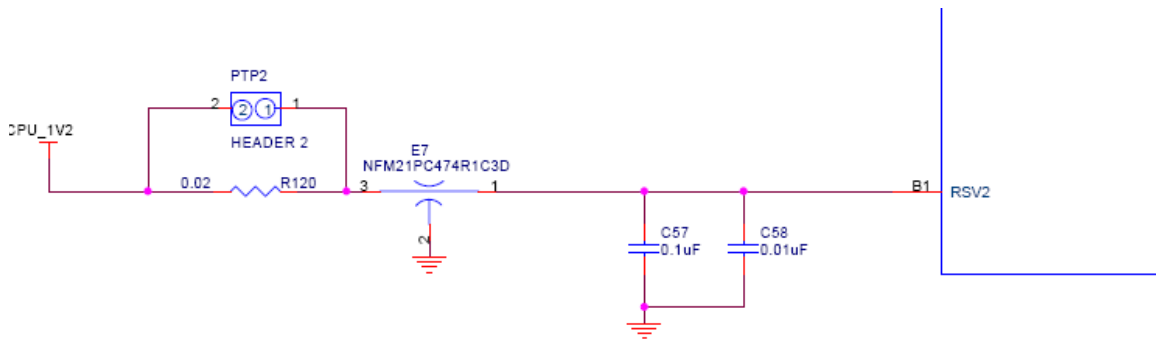

Revision D

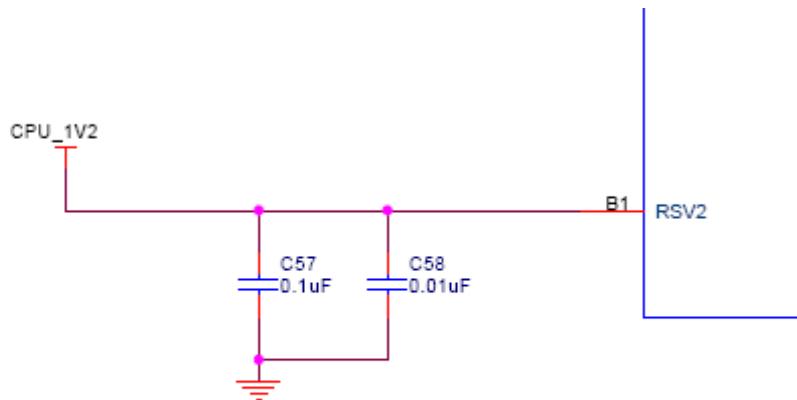

SHEET 14

Changed boot switch circuit for BOOTMODE[3].

Change allows all boot mode pins to be HIGH in the ON position, versus on Revision B where BOOTMODE[3] was high in the off position (SW3-position 5).

Only affects boot set up on Switch.

Added U60, U61, C273, C274, changed values of R126 and R124

Revision B

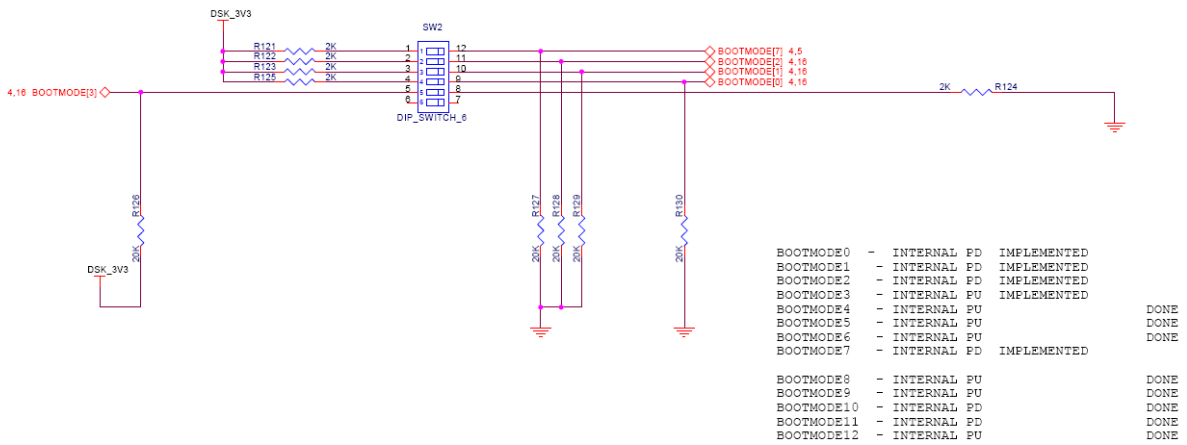

Revision D

