

NOTES, UNLESS OTHERWISE SPECIFIED:

1. RESISTANCE VALUES IN OHMS.
2. CAPACITANCE VALUES IN MICROFARADS.
3. REFERENCE DESIGNATORS USED:
4. ALL 0.1 uF AND 0.01uF CAPACITORS ARE DECOUPLING CAPS UNLESS OTHERWISE NOTED. THEY ARE SHOWN ON THE PAGE WITH THE INTEGRATED CIRCUITS THEY SHOULD BE PLACED NEAR.

REVISIONS			
Revision	DESCRIPTION	DATE	APPROVED
A	Initial Release.	5/15/09	
B	Changed USB Connector to type A, added Capacitance to 1.3Volt supply to reduce VCore Ripple	6/22/09	

Schematic Contents

- 01 - TITLE PAGE
- 02 - TMS320VC5505 GPIO / MMC / SPI / I2C -- SPI EEPROM
- 03 - TMS320VC5505 CLOCKS / JTAG / USB
- 04 - TMS320VC5505 EMIF
- 05 - TMS320VC5505 Power
- 06 - POWER 3V3, 1V3
- 07 - CODEC
- 08 - EXPANSION CONNECTOR
- 09 - XDS100 INTERFACE

REVISION STATUS OF SHEETS

REV	1	2	3	4	5	6	7	8	9	APPLICATION	USED ON	DATE	BY
SHEET													DWN R.R.P. 05/15/2009
REV													CHK T.W.K. 05/15/2009
SHEET													ENGR R.R.P. 05/15/2009
REV													ENGR-MGR R.R.P. 05/15/2009
SHEET													QA C.M.D. 05/15/2009
REV	A	A	A	A	A	A	A	A	A	NEXT ASSY	USED ON		MFG R.R.P. 05/15/2009
SHEET	1	2	3	4	5	6	7	8	9				RLSE R.R.P. 05/15/2009

SPECTRUM DIGITAL INCORPORATED			
Title: TMS320VC5505 eZDSP USB Stick			
Page Contents: TITLE SHEET			
Size: B	DWG NO	512322-0001	Revision: B
Date:	Thursday, June 25, 2009		Sheet 1 of 9

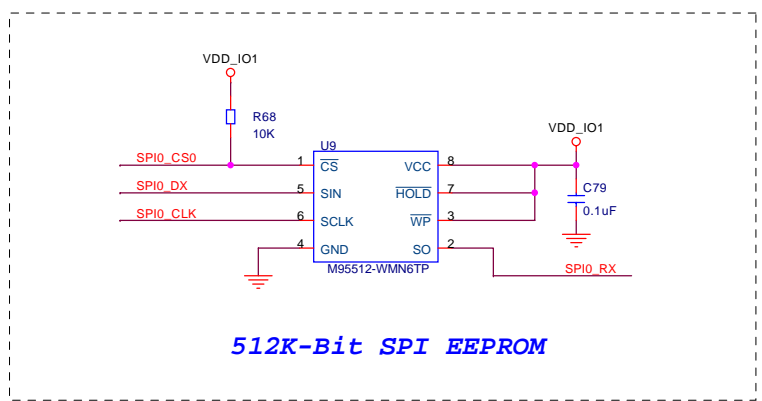
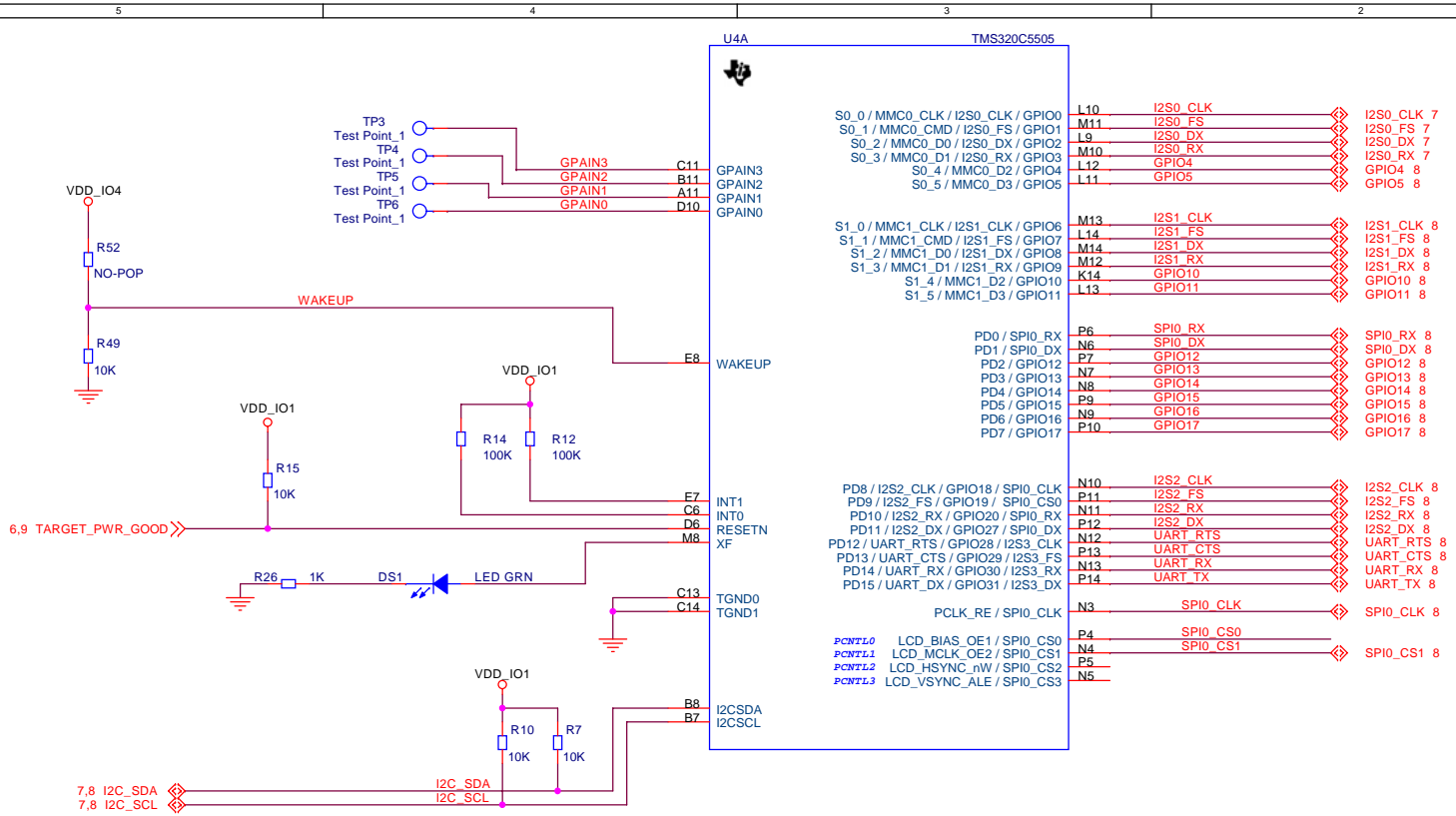

SPECTRUM DIGITAL INCORPORATED			
Title: TMS320VC5505 eZDSP USB Stick			
Page Contents: GPIO,MMC-SD,SPI,I2C,I2S			
Size:B	DWG NO	512322-0001	Revision: A
Date:	Tuesday, June 30, 2009	Sheet 2 of	9

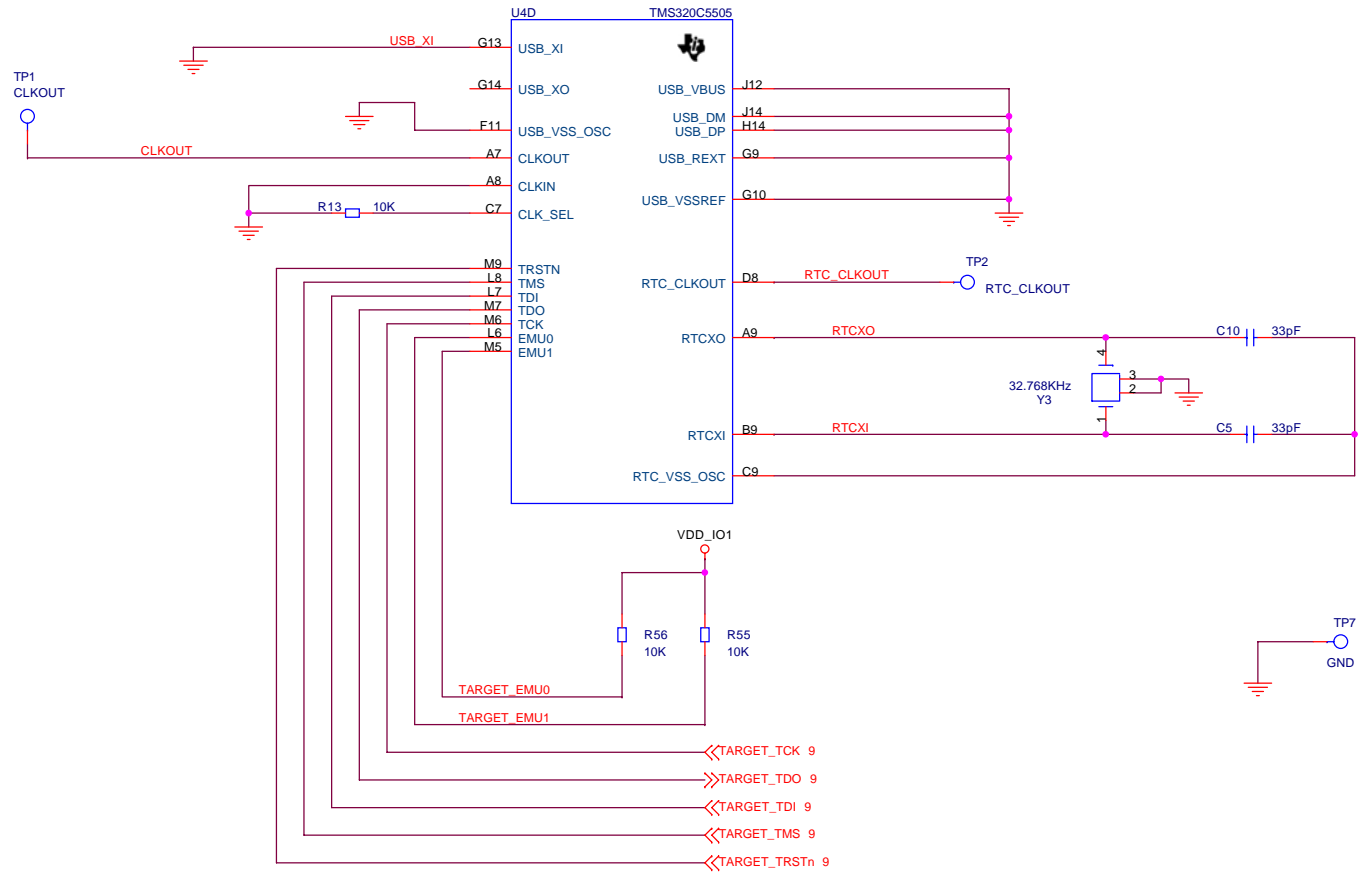

SPECTRUM DIGITAL INCORPORATED			
Title: TMS320VC5505 eZDSP USB Stick			
Page Contents: CLOCK,JTAG,USB			
Size: B	DWG NO	512322-0001	Revision: B
Date: Tuesday, June 30, 2009		Sheet 3 of 9	

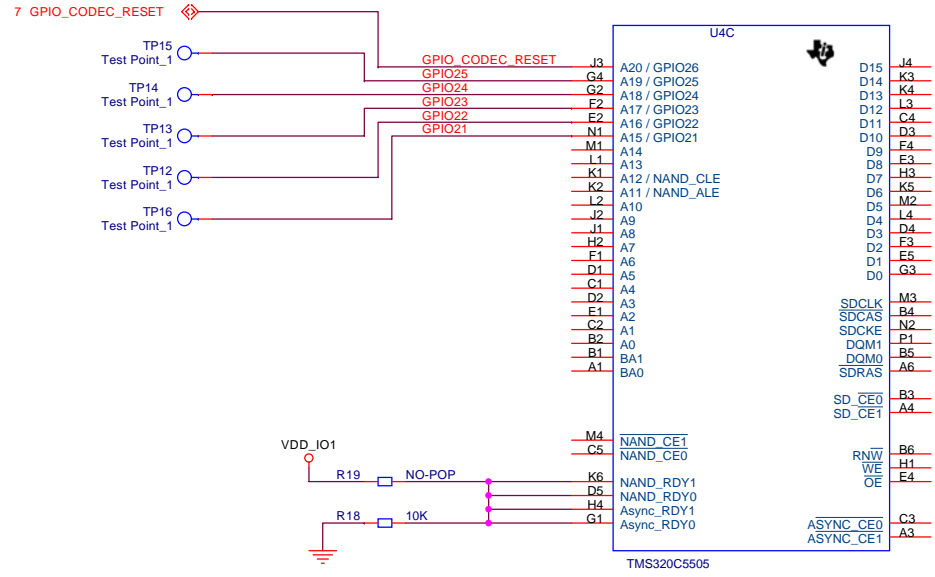

SPECTRUM DIGITAL INCORPORATED			
Title: TMS320VC5505 eZDSP USB Stick			
Page Contents: C5505 EMIF			
Size: B	DWG NO	512322-0001	Revision: A
Date:	Tuesday, June 30, 2009		Sheet 4 of 9

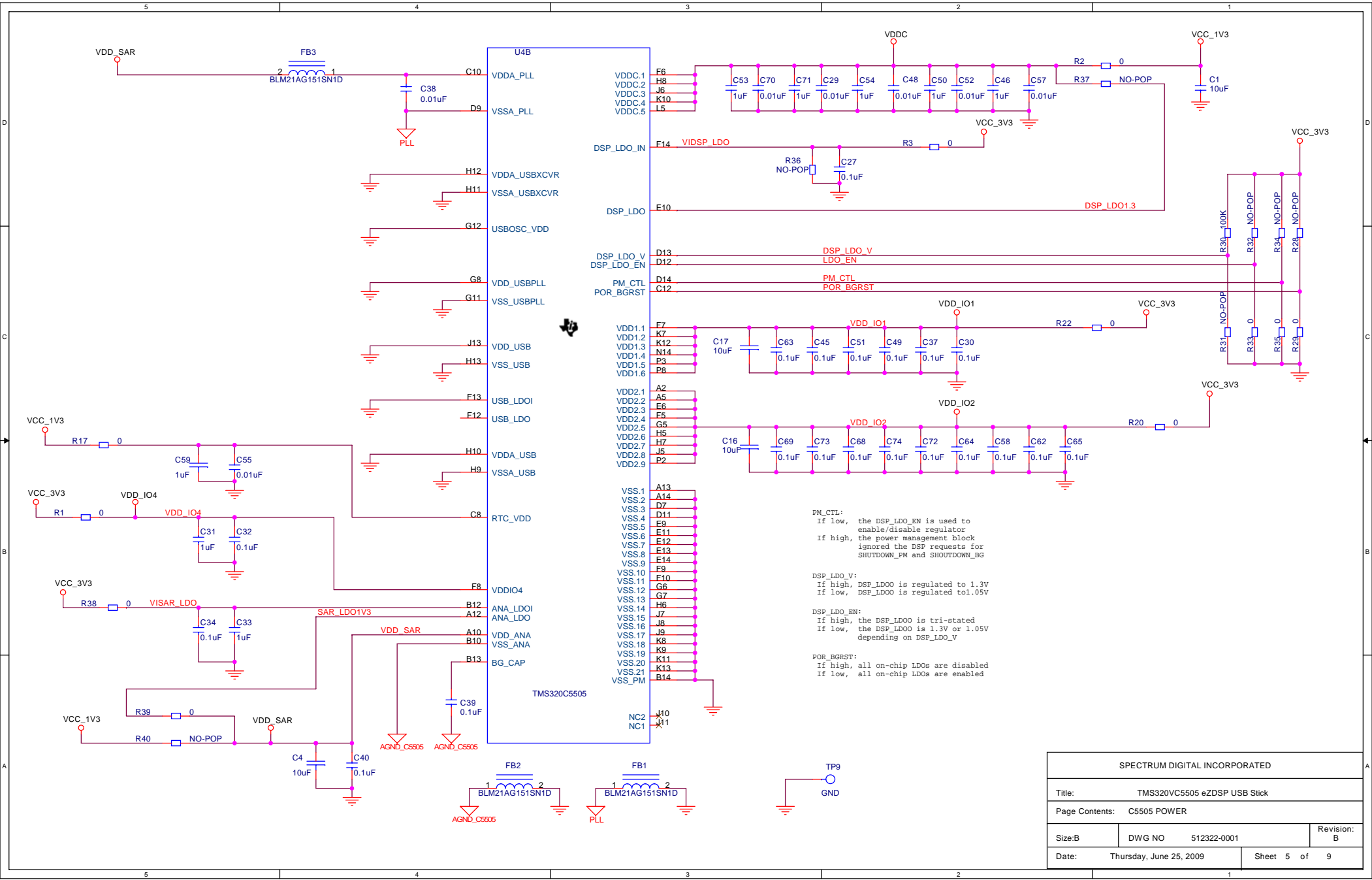

SPECTRUM DIGITAL INCORPORATED			
Title: TMS320VC5505 eZDSP USB Stick			
Page Contents: C5505 POWER			
Size: B	DWG NO	512322-0001	Revision: B
Date:	Thursday, June 25, 2009	Sheet 5 of	9

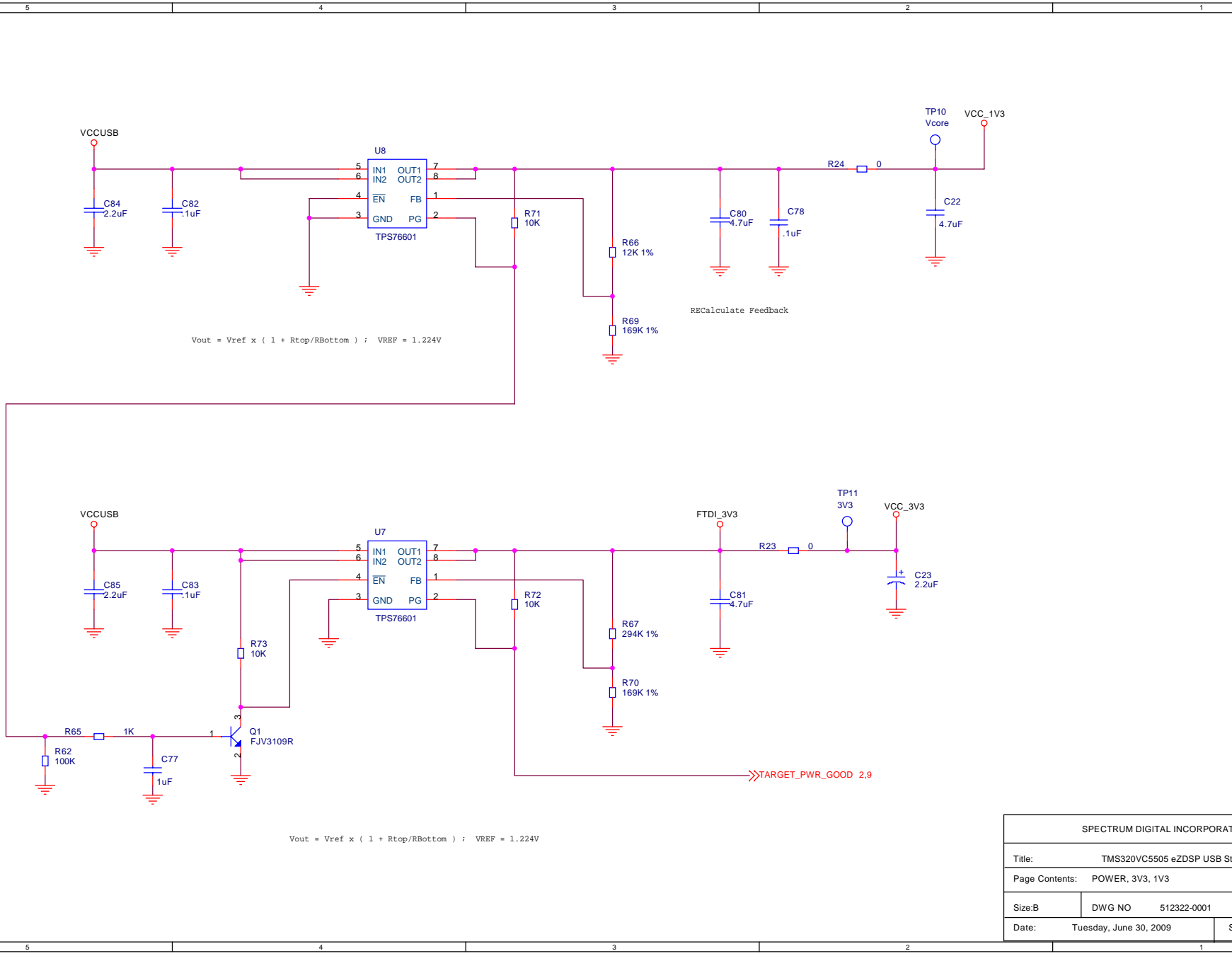

SPECTRUM DIGITAL INCORPORATED			
Title: TMS320VC5505 eZDSP USB Stick			
Page Contents: POWER, 3V3, 1V3			
Size: B	DWG NO	512322-0001	Revision: B
Date:	Tuesday, June 30, 2009		Sheet 6 of 9

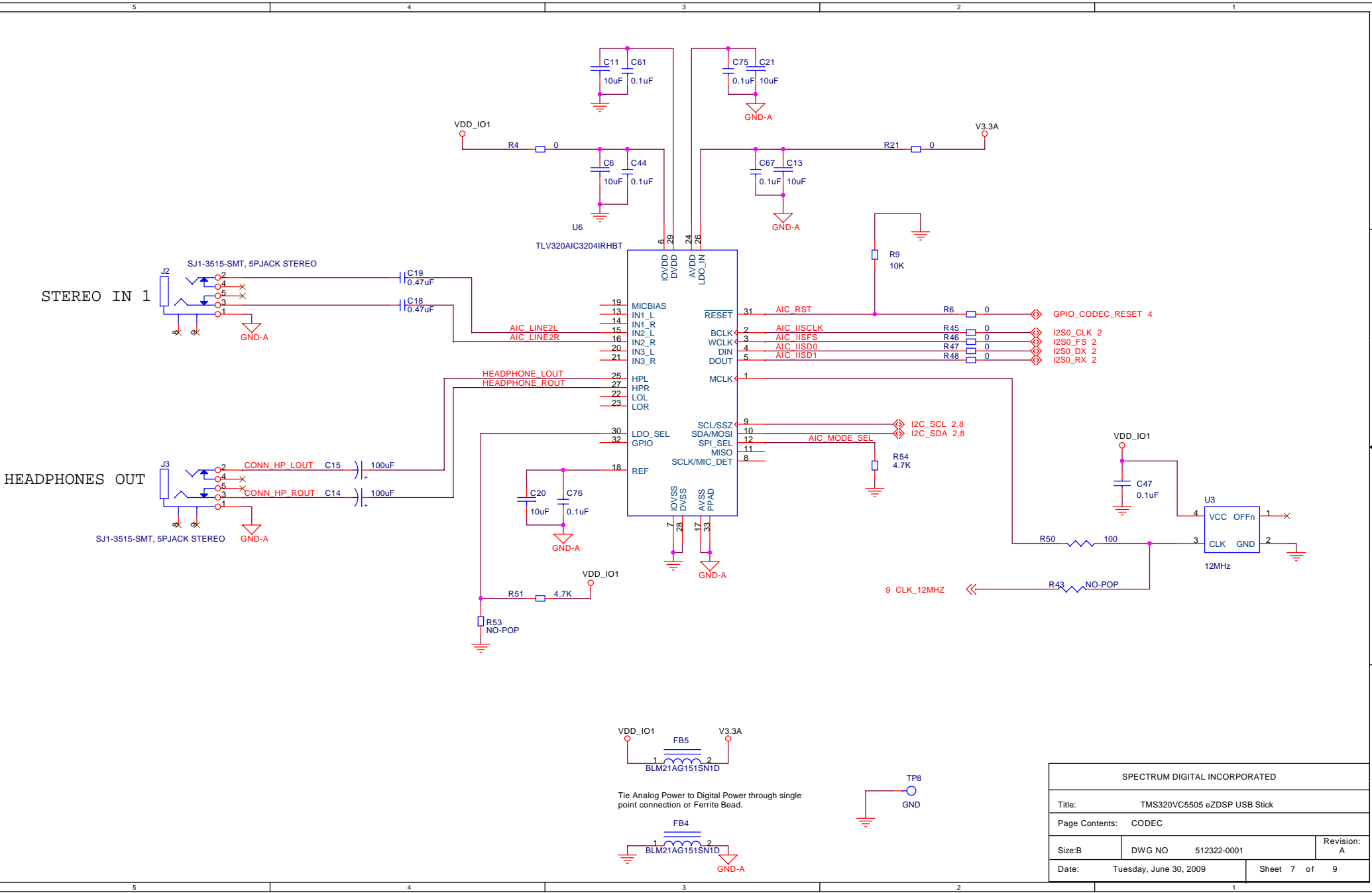

Tie Analog Power to Digital Power through single point connection or Ferrite Bead.

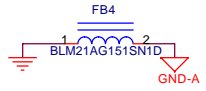

SPECTRUM DIGITAL INCORPORATED			
Title: TMS320VC5505 eZDSP USB Stick			
Page Contents: CODEC			
Size: B	DWG NO: 512322-0001	Revision: A	
Date: Tuesday, June 30, 2009	Sheet 7 of 9		

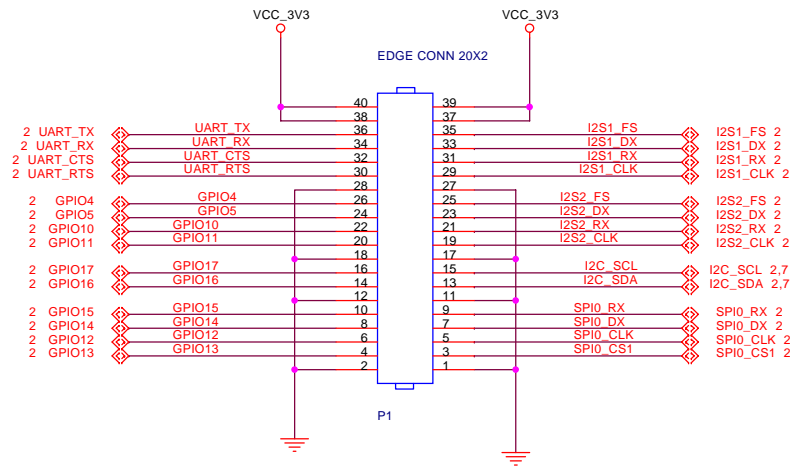

SPECTRUM DIGITAL INCORPORATED			
Title: TMS320VC5505 eZDSP USB Stick			
Page Contents: EXPANSION CONNECTORS			
Size: B	DWG NO	512322-0001	Revision: A
Date:	Tuesday, June 30, 2009	Sheet 8 of	9



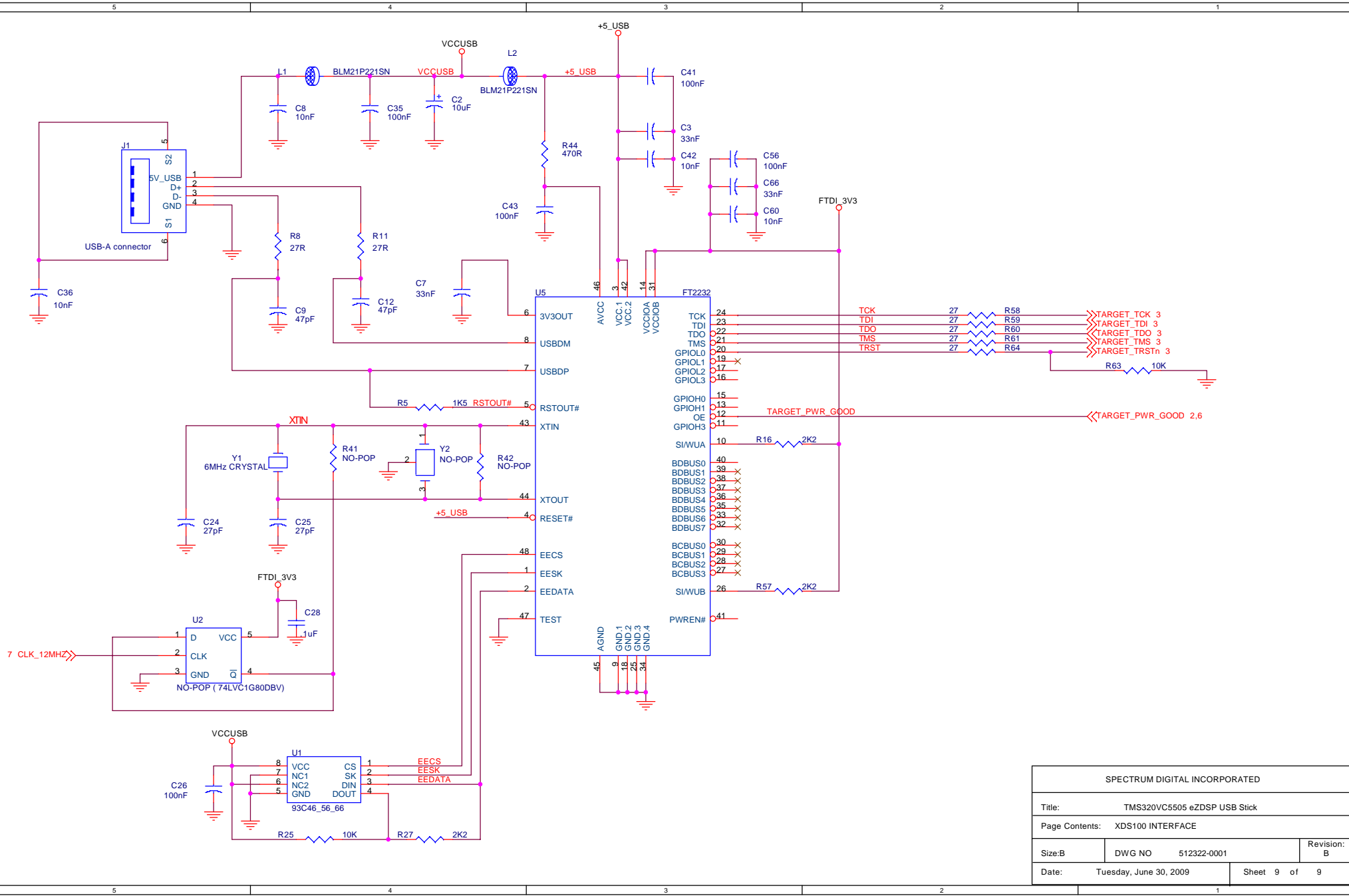

SPECTRUM DIGITAL INCORPORATED			
Title: TMS320VC5505 eZDSP USB Stick			
Page Contents: XDS100 INTERFACE			
Size: B	DWG NO: 512322-0001	Revision: B	
Date: Tuesday, June 30, 2009	Sheet 9 of 9		