

XDS560v2 LC Traveler JTAG Emulator for CCS 4.2 or Higher

Quick Start Installation Guide

Kit Contents



XDS560v2
LC Traveler

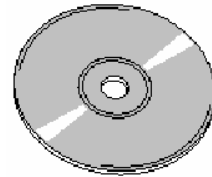

Driver DVD



CTI20 - T114



USB Cable

System Requirements

- Microsoft Windows™ XP/Vista/7 or Linux
- 2 GB of free hard disk space
- Minimum 1 GB RAM, 2 GB recommended
- Minimum 1.5 GHz, dual core recommended
- Color display
- Internet Access
- One PC USB port or a powered USB hub with one port
- DVD reader

Service and Support

Web	http://support.spectrumdigital.com
E-Mail	support@spectrumdigital.com

The driver install supports the Spectrum Digital XDS560v2 LC Traveler JTAG Emulator in a CCS 4.2 or higher environment. Emulation drivers are updated on a regular basis so check the Spectrum Digital web site at support.spectrumdigital.com. The XDS560v2 LC Traveler JTAG Emulator will be referred to as the XDS560v2.

Installation Overview

Installing the XDS560v2 LC Traveler is 3 step process:

1. Installing the Code Composer Studio™ software
2. Configuring the emulator tail with correct target adapter.
3. Installing the USB connection to the host PC.

Installing the Code Composer Studio software

1. Code Composer Studio should be installed before starting the hardware installation. Please refer to the Code Composer Studio software installation guide for the installation of Code Composer Studio. The baseline Spectrum Digital emulation drivers are included in CCS v4.2 and higher and these should be installed. XDS560v2 LC Traveler driver updates are included on the driver CD.
2. Additional documentation is on the driver CD included with your XDS560v2 Traveler LC product.

Configuring the Emulator Tail

1. The emulator tail is the physical interface between the emulator and target board. The tail configuration will consist of 2 parts:
 - Emulator tail header
 - *Optional CTI20 to TI14 adapter*
2. The female JTAG header attached to the end of the emulator tail plugs onto the target's male pin header. The figure below shows how the XDS560v2 LC Traveler emulator header plugs onto the target's JTAG header.

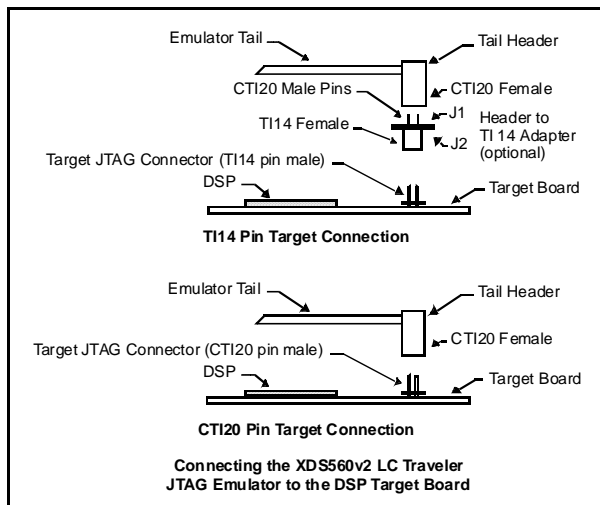

3. The figure below shows the TI14 pin adapter plugged into the CTI20 header.

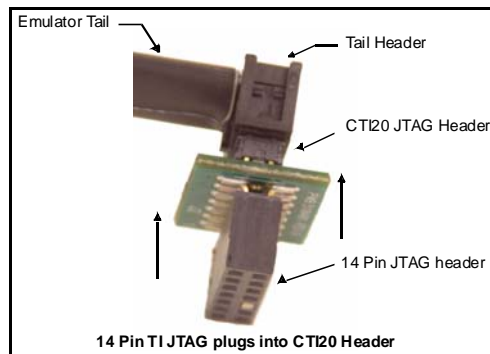

Installing the USB connection to the host PC

This section provides instructions to install the XDS560v2 LC Traveler JTAG emulator using the USB interface.

1. Turn off the power to your target board.
2. The XDS560v2 LC Traveler must be connected to the host PC by the supplied USB cable. Connect the supplied USB cable to your PC or laptop. The XDS560v2 LC Traveler may be used with a **powered** USB hub.
3. Connect the other end of the USB cable to the XDS560v2 LC Traveler.

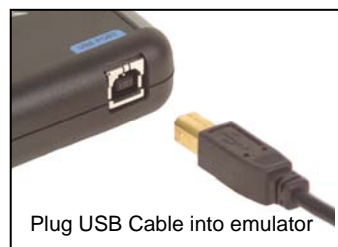

When the USB cable is properly connected the "PWR" LED on the XDS560v2 LC Traveler should illuminate. After about 45 seconds LED "State 3" should come on. At this point the XDS560v2 LC Traveler has booted its operating system and is ready for connecting via USB.

If this is the first connection over the USB the Windows Hardware Wizard should find the XDS560v2 LC Traveler and install its USB drivers.

- Now connect the tail of the emulator to the JTAG header on your target board. If your target board requires a different interface than the CTI20 header, attach the CTI to 14 pin adapter.

Caution should be used in the routing of the tail ribbon cable to insure it does not go near the processor(s), power traces, or power cords.

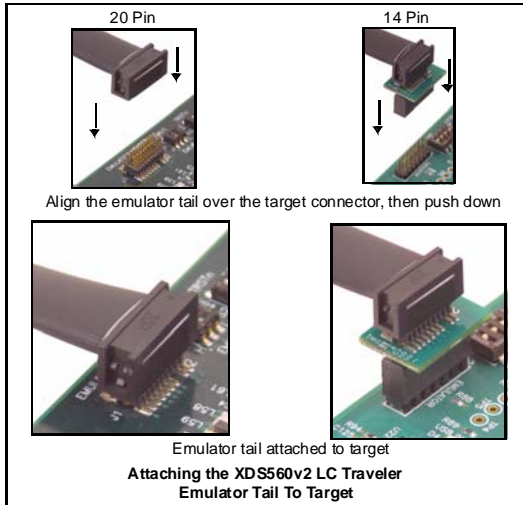

- Apply power to the target board.
- Please refer to the XDS560v2 LC Traveler Technical Reference Manual for the typical system configurations.

Configuring CCS v4/v5

To configure CCS v4/v5 to use the XDS560v2 LC Traveler emulator follow the CCS v4/v5 instruction for creating a "New Target Configuration". When selecting the emulator select the following:

"Spectrum Digital XDS560V2 LC Traveler Emulator"

For USB the default "Emulator I/O Port Number" of 0 should be used when connecting to a single XDS560v2 LC Traveler.

Notes:

- The XDS560v2 LC Traveler configuration is set up to mimic XDS510USB PLUS settings. These settings have proven to work best for a wide range of targets in a production test environment.
- The standard XDS560v2 STM USB configuration can be used on the XDS560v2 LC Traveler and vice versa.

Troubleshooting

When power is applied to the XDS560v2 LC Traveler via the dual headed USB cable it will begin booting its OS and provide a visual indication of its progress and also indicate if booting for normal operation or into safe mode. The boot manager will go to Safe Mode if it detects a problem during OS boot or a potential hardware problem with the XDS560v2 LC Traveler. When in Safe Mode you cannot run CCS instead you can use the **Sd560v2Cnfg** utility to diagnose the problem and return to normal boot mode. The following sequences with approximate timings are provided for reference. From the sequences you can see that it may take the XDS560v2 LC Traveler around 40 seconds to boot so during this time do not power cycle the unit.

Normal Boot Progress:

LED Activity	Sequence Events
POWER.....ON	time0
ACTIVITY-1...ON	time0 + 3 seconds : Linux + Application booting
STATE-3.....ON	time0 + 39 seconds : Communications application running
ACTIVITY-1...OFF	time0 + 39 seconds : Boot process complete

Safe Mode Boot Progress:

LED Activity	Sequence Events
POWER.....ON	time0
ACTIVITY-1...ON	time0 + 3 seconds : Linux + Application booting
STATE-3.....ON	time0 + 4 seconds : Linux boot to Safe Mode
ACTIVITY-1, STATE-3 OFF	time0 + 39 seconds : Safe Boot process complete